

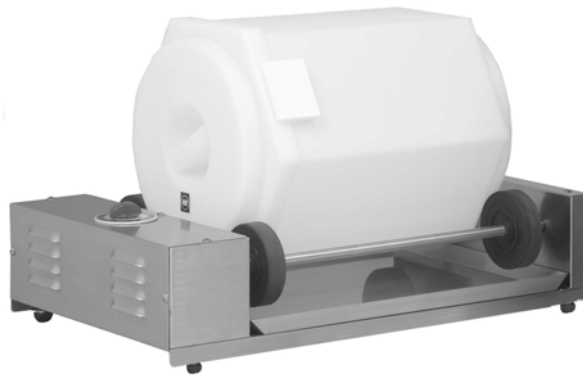

OPERATION, SERVICE & PARTS MANUAL
BROASTER® 620NXP & 621
EASY BREADER

Be sure ALL installers read, understand, and have access to this manual at all times.



MODEL 620NXP

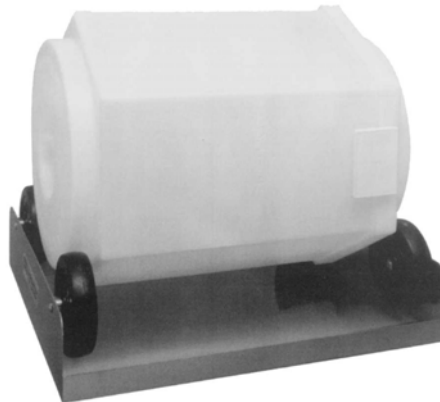

MODEL 621

Genuine Broaster Chicken®, Broasted®, Broaster Chicken®, Broaster Foods®, and Broasterie® are registered trademarks. Usage is available only to licensed operators with written authorization from the Broaster Company.

Broaster Company
2855 Cranston Road, Beloit, WI 53511-3991
608/365-0193 broaster.com

FOR YOUR SAFETY

Do not use or store gasoline or other flammable vapors or liquids in the vicinity of this or any other appliance.

⚠ WARNING

Improper installation, adjustments, alteration, service or maintenance can cause property damage, injury or death. Read the installation, operating and maintenance instructions thoroughly before installing or servicing this equipment.

For the sake of safety and clarity, the following words used in this manual are defined as follows:

⚠ DANGER

Indicates an imminently hazardous situation which, if not avoided, could result in serious injury or death.

⚠ WARNING

Indicates a potentially hazardous situation which, if not avoided, could result in serious injury or death.

⚠ CAUTION

Indicates a potentially hazardous situation which, if not avoided, could result in minor injury, property damage or both.

All adjustments and repairs shall be made by an authorized Broaster Company representative.

If there is a power failure, turn power switch OFF. DO NOT attempt to operate unit during a power failure.

⚠ WARNING

Failure to read and understand this manual completely could result in serious injury or death. Be sure ALL operators read, understand and have access to this manual at all times.

⚠ WARNING

Rags or paper containing cooking oil can catch fire if exposed to heat. Laundering will not remove the oil. Dispose of all oil-soiled papers and rags in a trash container that is in a ventilated area away from all cooking equipment or other heat sources such as direct sunlight.

TABLE OF CONTENTS

1 – LIMITED WARRANTY	1-1
2 – ELECTRICAL	2-1
CONNECTIONS	2-1
3 – OPERATION	3-1
4 – SERVICE	4-1
TIMER REPLACEMENT	4-1
30 Minute Timer	4-1
10 Minute Timer	4-1
DRIVE MOTOR REPLACEMENT	4-2
5 – PARTS	5-1
Model 620N Breader Base Parts	5-1
Model 621 Manual Breader Parts	5-2
Breaders Drum Parts	5-2

1 - LIMITED WARRANTY

Subject to the terms and conditions of this warranty, The Broaster Company (Company) warrants that all equipment and parts manufactured and sold by the Company and purchased new from an authorized Broaster Distributor or Export Management Company are free from defects in material and workmanship for a period of one year from date of installation if installation is made by a qualified installer in accordance with applicable laws and regulations. Warranty coverage is extended to the original purchaser only and is void if the equipment is resold. If an authorized Company Distributor or Export Management Company notifies The Broaster Company Service Department of a warranty claim during the warranty period, and there is a warranty registration on file with the matching serial number, the Company will, upon receipt of the claim and clear photographs of the failed part, examine the information and determine if the claim can be processed without the return of the part. If the claim is deemed to be valid, the Company will then issue a credit for the price of a new part to the Distributor or Export Management Company. In some cases, at the sole discretion of the Company, it will be required that the part be returned before a claim can be processed. A claim will be considered invalid if there is any evidence that the part had been subjected to abnormal usage, had not been installed, operated or serviced in accordance with Company operating instructions, or if there is any evidence of accident, alteration or abuse of the part or the use of unauthorized repair methods. All parts replaced under this warranty carry only the unexpired term of the warranty.

This warranty covers parts only and does not cover labor charges, transportation charges or other expenses in the connection with warranty service, which are the obligation of the owner unless otherwise specified in the original sales contract between the purchaser and the authorized Company Distributor or Export Management Company from which the equipment is purchased. Please refer to that contract for coverage as to those charges.

This warranty does not apply to consumable items and supplies such as O-rings, brushes, food baskets, bulbs, gaskets and lamps.

The foregoing warranty is made in lieu of all other warranties, expressed or implied, and the Company specifically disclaims any implied warranties of merchantability or fitness for a particular purpose. The company's full obligation under this warranty, and the purchaser's sole remedy, shall be limited to credit for returned parts as specified above.

IN NO EVENT SHALL THE COMPANY BE LIABLE TO THE ORIGINAL OWNER OR ANY OTHER PERSON FOR ANY INCIDENTAL, CONSEQUENTIAL OR SPECIAL DAMAGES RESULTING FROM THE USE OR INABILITY TO USE THE EQUIPMENT COVERED HEREBY, WHETHER ARISING FROM BREACH OF WARRANTY, STRICT LIABILITY OR OTHERWISE.

The Company reserves the right to change or improve its product in any way without obligation to alter products previously manufactured.

Used Company equipment or Company equipment not purchased from an authorized source carries no warranty, expressed or implied.

2 - ELECTRICAL

CONNECTIONS

Use input voltage as shown on rating plate. Breader current rating is 1 Amp. Use a circuit with a fuse rating of at least 15 Amps.

⚠ WARNING For your safety, the wall receptacle must be of the grounding type, properly connected. This type will accept the 3-prong plug supplied with the Breader. If a plug adapter must be used, be sure that its ground wire is grounded.

The Breader can now be operated with maximum safety because the safety wire in power cord is connected to a true ground.

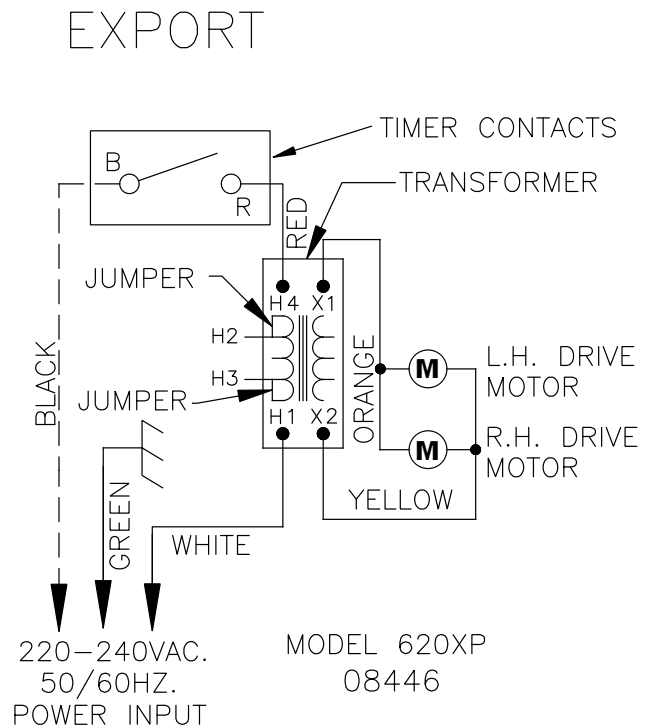
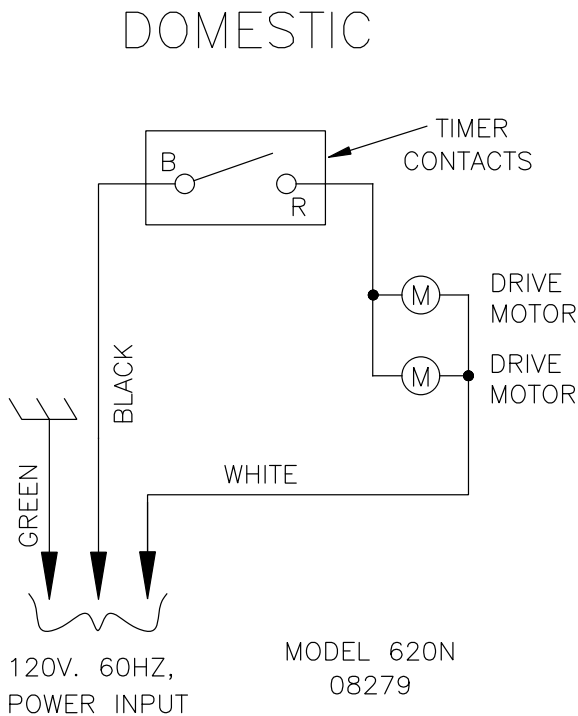

3 - OPERATION

1. Dust the bottom of drum with breading and place chicken in a circular fashion on top of breading, then put more breading on chicken and more chicken on breading in a circular fashion. Continue this procedure until drum is loaded. Start by using 2 cups of breading per 36 pieces of chicken. From there you can adjust the amount of breading to taste.
2. Place cover on drum and secure it.
3. Place drum assembly onto breeder. On the Model 620, set timer for 3 minutes. On the Model 621, manually rotate drum assembly continuously for 3 minutes.
4. While product in one drum is breading on Model 620, a second drum may be prepared for breading.
5. When 3 minutes are up, remove drum assembly from breeder and remove cover.
6. Remove contents from drum. Shake excess breading off chicken and place in a pan.
7. For best results, allow product to set up under refrigeration for 45 minutes minimum to **24** hours maximum before cooking. Do not exceed **24** hours or dark coating may result. Cover chicken loosely to prevent it from drying out.

4 - SERVICE

1. Disconnect power cord.
2. Pull timer knob (1) off.
3. Remove screws (2) from control box.
4. Disconnect wires from timer.
5. Remove mounting nut (3) from timer shaft.
6. Remove timer.
7. Install new timer in reverse order.

10 Minute Timer

NOTICE This timer is no longer available. To replace this timer order replacement kit #70104 and follow the instructions in the kit.

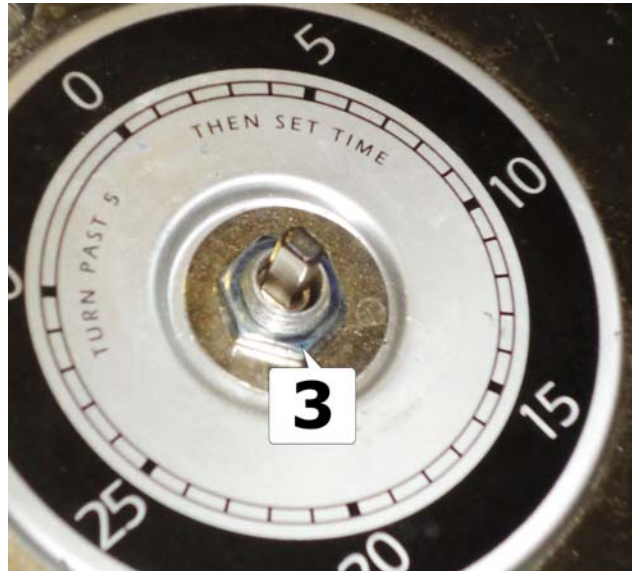
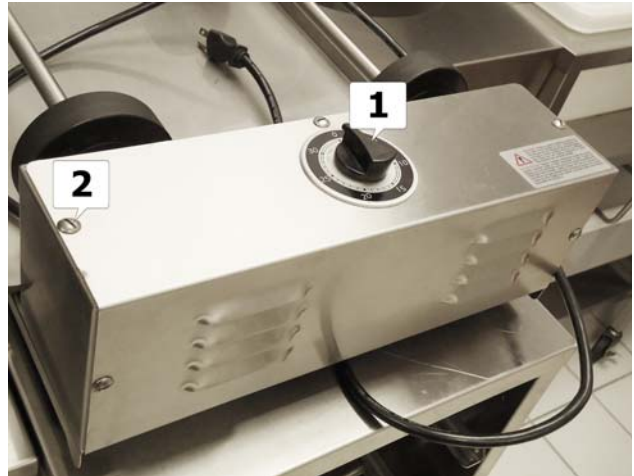

DRIVE MOTOR REPLACEMENT

1. Disconnect power cord.
2. Remove screws (2) from control box.
3. Remove bridge pin (4) and mounting screws (5).
4. Disconnect motor wiring and pull out defective motor.
5. Install new motor by sliding the drive shaft through the hole in the box and into the end of the wheel shaft.
6. Install mounting screws (5).
7. If the new motor does not have a hole in the shaft for the bridge pin, using the hole in the wheel shaft, drill a 1/8" diameter hole through the motor drive shaft.
8. Insert the bridge pin (4).
9. Rewire the motor (see wiring diagram on page 2-1).
10. Reinstall the control box cover with screws (2).
11. Reconnect power cord.

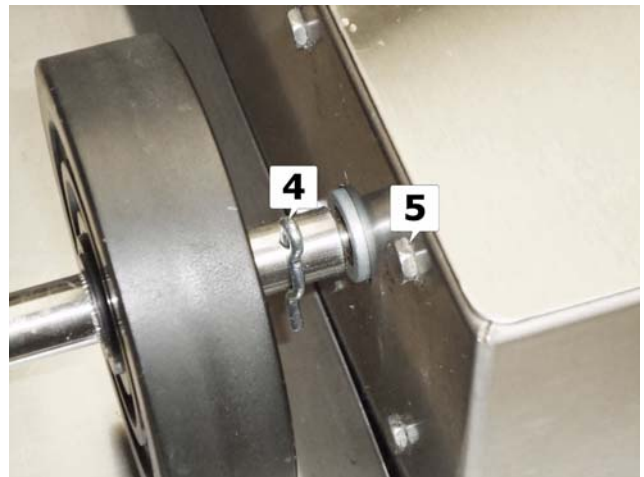

5 - PARTS

Model 620N Breader Base Parts

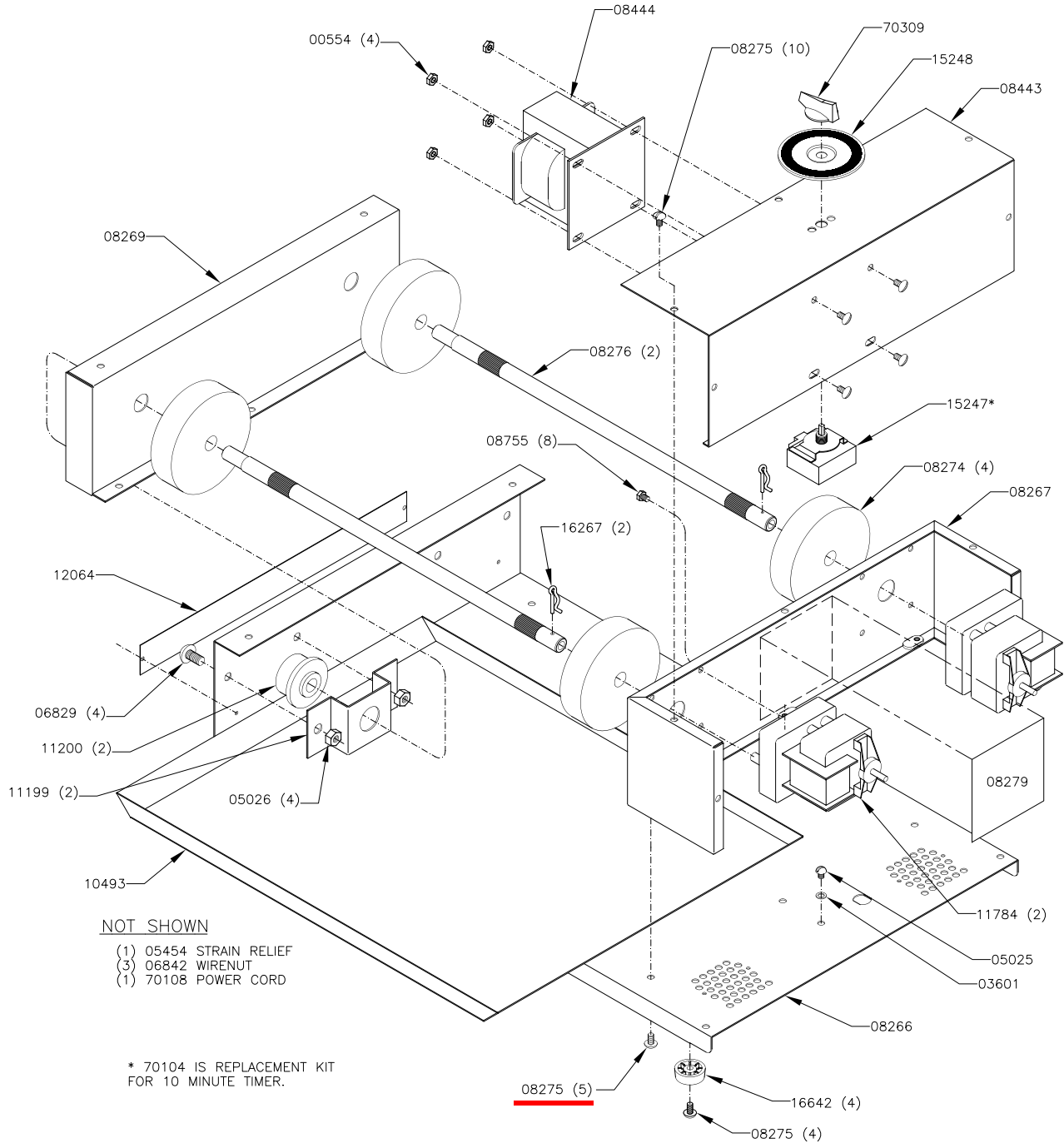

Model 621 Manual Breader Parts

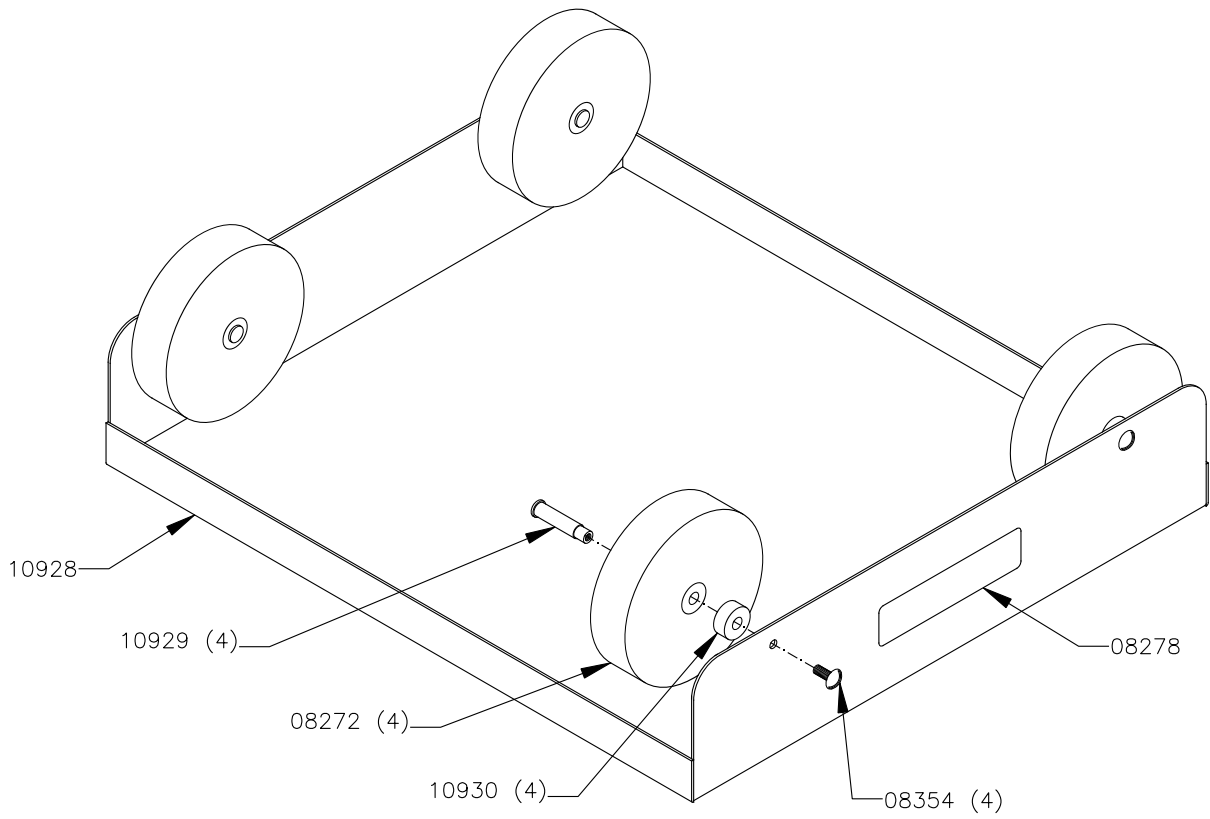

Breader Drum Parts

DRUM ASSEMBLY 08282
INCLUDES ALL OF THE
ABOVE PARTS.

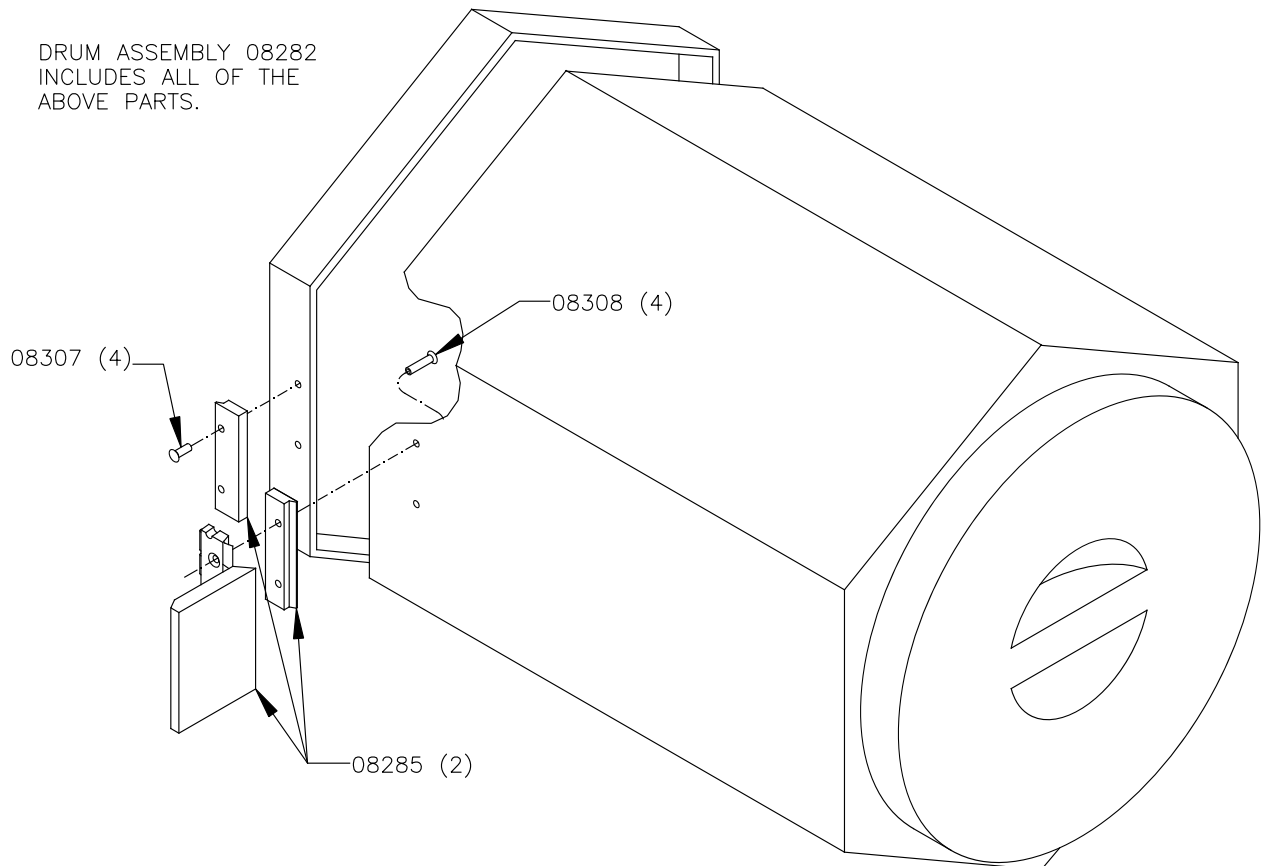



Broaster Company
2855 Cranston Road, Beloit, WI 53511-3991
608/365-0193
broaster.com