

BROASTER[®]

EQUIPMENT

OPERATION MANUAL

BROASTER[®] 1600 AND 1800

PRESSURE FRYER

Be sure ALL installers read, understand, and have access to this manual at all times.

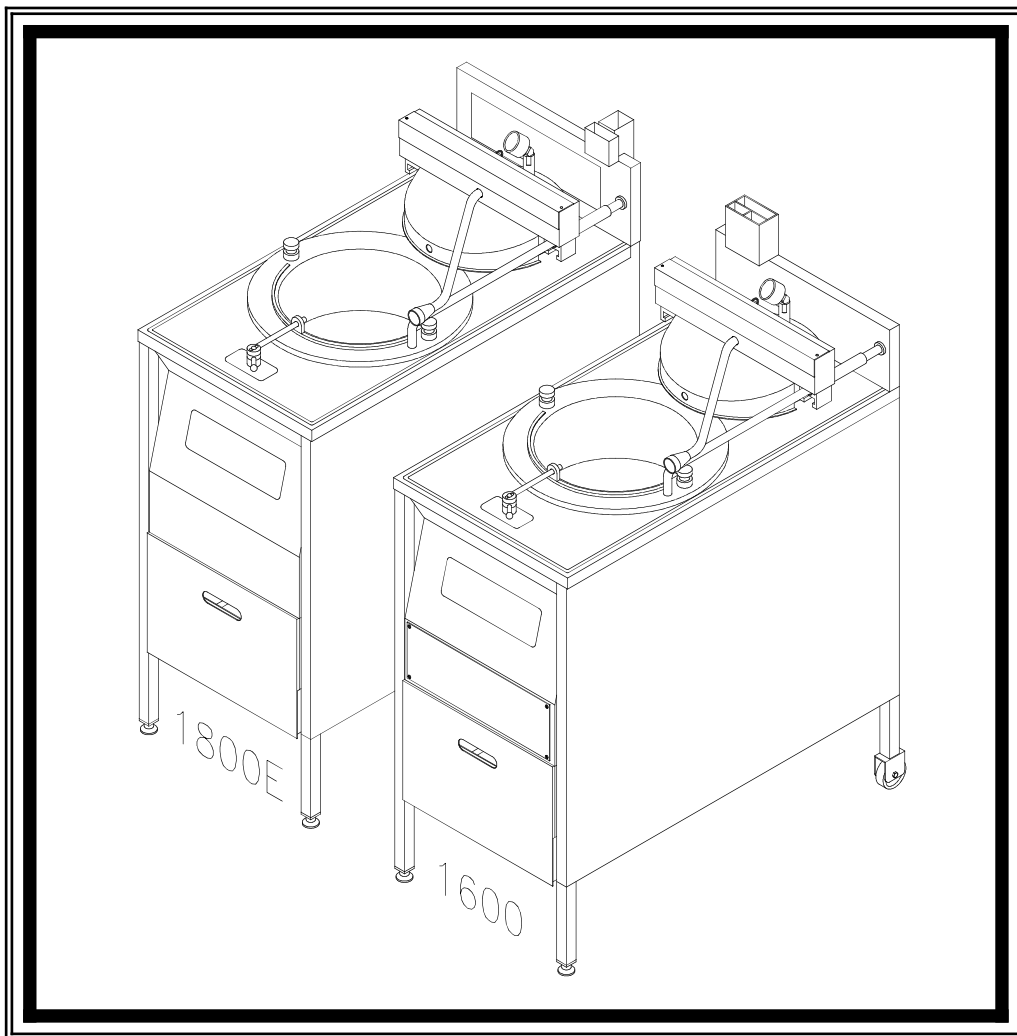

Genuine Broaster Chicken[®], Broasted[®], Broaster Chicken[®], Broaster Foods[®], and Broasterie[®] are registered trademarks. Usage is available only to licensed operators with written authorization from The Broaster Company.

Broaster Company
2855 Cranston Road, Beloit, WI 53511-3991
608/365-0193 broaster.com

Design Certified By:
1600: NSF and UL
1800: NSF and UL

Manual #14679 9/19 Rev 11/25

© 2001 Broaster Company
Printed In U.S.A.

FOR YOUR SAFETY

Do not use or store gasoline or other flammable vapors or liquids in the vicinity of this or any other appliance. Improper installation, adjustments, alteration, service or maintenance can cause property damage, injury or death. Read the installation, operating and maintenance instructions thoroughly before installing or servicing this equipment.

For the sake of safety and clarity, the following words used in this manual are defined as follows:



Indicates an imminently hazardous situation which, if not avoided, will result in serious injury or death.



Indicates a hazardous situation which, if not avoided, could result in serious injury or death.



Indicates a hazardous situation which, if not avoided, could result in minor or moderate injury.

All adjustments and repairs shall be made by an authorized Broaster Company representative.

If there is a power failure, turn cook/filter switch OFF. On the Model 2400GH, also slide switch on gas valve OFF. DO NOT attempt to operate unit during a power failure.



Failure to read and understand this manual completely could result in serious injury or death. Be sure ALL operators read, understand and have access to this manual at all times.



Rags or paper containing cooking oil can catch fire if exposed to heat. Laundering will not remove the oil. Dispose of all oil-soiled papers and rags in a trash container that is in a ventilated area away from all cooking equipment or other heat sources such as direct sunlight.



If at any time the POWER ON light does not turn off when the cook/filter switch is moved to the OFF position, disconnect the power to the fryer and contact your local Broaster Company representative for service immediately.



DO NOT operate unit without filter pan and filter pan cover in its proper position. Filter pan cover must be wiped clean after each filtering cycle.



Make sure Pressure Relief Valve and Pressure Gauge ports on bottom of cover are clear of any oil or grease buildup.

1600 Mechanical Controls:



If at any time the unit fails to operate properly when the cook/filter switch is moved to the cook position, contact your local Broaster Company representative for service immediately.

cont'd on next page

1600/1800E Solid State Controls:

⚠ WARNING If at any time the **POWER ON** light does not turn off when the cook/filter switch is moved to the **OFF** position, disconnect power to the fryer and contact your local Broaster Company representative for service immediately.

1800GH:

Post, in prominent locations, instructions to be followed in the event that the user smells gas. This information can be obtained from your local gas supplier.

⚠ WARNING Make sure a restraining device is used that complies with the Standard for *Commercial Gas Ranges, ANSI Z83.11/ CSA 1.8* to guard against transmission of strain to the gas connectors.

⚠ DANGER Failure to restrain the fryer could allow it to move, causing hot shortening to spill out, or a possible break in the gas line causing an explosive condition.

1 - LIMITED WARRANTY - Parts and Labor

Subject to the terms and conditions of this warranty, The Broaster Company (Company) warrants that all equipment and parts manufactured or sold by the Company and purchased new from an authorized Company distributor are free from defects in material and workmanship. The warranty begins on the date of installation, or one year from the date of manufacture, whichever occurs earlier. The term of the warranty is **one year for all non-wearable parts, two years on Solid State controllers, and ten years on the Welded Stainless Steel Cooking Well**. To qualify for warranty coverage, all units must be installed by a qualified installer under supervision by an authorized distributor in accordance with applicable laws and regulations. Warranty coverage is extended to the original purchaser only and is void if the equipment is resold or relocated. If an authorized Company distributor is notified of a warranty claim during the warranty period, the Company will at its option replace, recondition, or repair at its factory any part or parts of the equipment which the Company judges defective, provided the equipment has been subjected to normal usage, properly installed, operated and serviced in accordance with Company operating instructions, and there is no evidence of accident, alteration or abuse of the equipment or the use of unauthorized repair methods. All parts replaced under this warranty carry only the unexpired term of the warranty.

Extended cooking well warranty will cover the cooking well only and does not include any parts attached to the cooking well, including: probe guards, basket guides, latch columns, latch column blocks, insulation, splash shield interlock, drain valve, filter lines and fittings, high limit, thermostat, temperature sensor probe, combustion chamber and flue, elements, burner, all mounting hardware. The aforementioned excluded parts are covered under the 1-year parts warranty. The extended warranty does not cover any cooking well that fails due to any misuse or abuse.

Any warranty claim on the cooking well must be presented to The Broaster Company or authorized Broaster Distributor from whom the pressure fryer was purchased. Repairs will be made by The Broaster Company only. Any freight charges and distributor labor costs to install the repaired cooking well, as well as the cost of any other parts replaced will be the responsibility of the equipment owner.

Service under this warranty shall be furnished only by an authorized Company distributor. The Company does not send service representatives to furnish warranty service. Your authorized Company distributor should be contacted for warranty service.

This warranty covers **on-site labor charges and one-way travel charges with a 150-mile maximum only**, at a fixed rate, for one year, on new equipment only. The warranty coverage is for one trip only. Additional trips to resolve the same problem will not be covered. The warranty period begins on the date of installation or one year from the date of manufacture, whichever occurs earlier. Transportation charges, trip charges, zone fees, or other expenses in connection with warranty service are the obligation of the owner.

This warranty shall be void unless genuine Broaster® parts & filter paper, Bro-Clean™ filtering compound, and Broaster Cooking Well Cleaner is used in conjunction with the equipment.

This warranty does not apply to consumable items and supplies such as O-rings, food baskets, bulbs, gaskets and lamps.

The foregoing warranty is made in lieu of all other warranties, express or implied, and the Company specifically disclaims any implied warranties of merchantability or fitness for a particular purpose. The Company's full obligation under this warranty, and the purchaser's sole remedy, shall be limited to replacement, reconditioning or repair as specified above.

IN NO EVENT SHALL THE COMPANY BE LIABLE TO THE ORIGINAL OWNER OR ANY OTHER PERSON FOR ANY INCIDENTAL, CONSEQUENTIAL OR SPECIAL DAMAGES RESULTING FROM THE USE OR INABILITY TO USE THE EQUIPMENT COVERED HEREBY, WHETHER ARISING FROM BREACH OF WARRANTY, STRICT LIABILITY OR OTHERWISE.

The Company reserves the right to change or improve its products in any way without obligation to alter products previously manufactured.

Used Company equipment or Company equipment not purchased from an authorized distributor carries no warranty expressed or implied.

18. **Pressure Port:** When cover is CLOSED while cooking, all steam passes through this port into the pressure regulating valve.

19. **Capillary Guard:** This guard protects temperature sensor probe, hi-limit bulb and capillary from damage.

CAUTION Check oil level before turning cook/filter switch to COOK.

20. **1600/1800E Hot Oil Level:** Indicates proper level when oil is at operating temperature. 1800GH: HOT OIL LEVEL is stamped on capillary guard.

Model 1600:

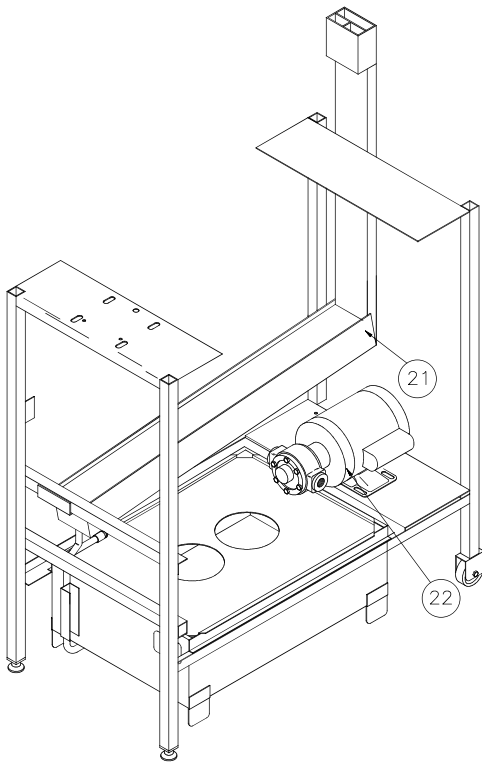

Model 1800:

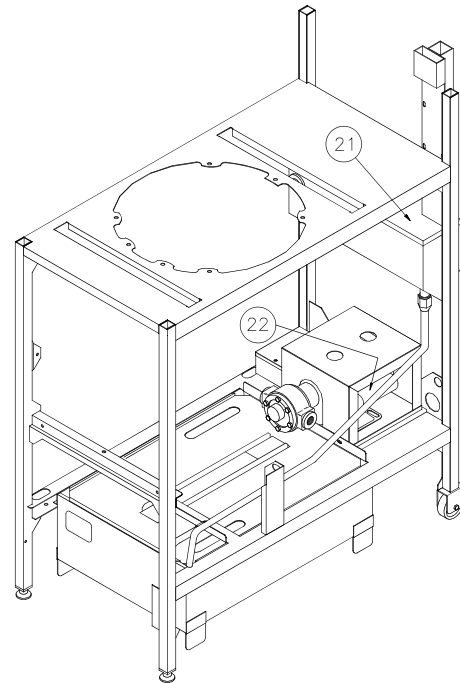

21. **Exhaust Tank:** Steam and vapors are exhausted through this tank.

22. **Filter Pump and Motor:** When filtering, returns oil to cooking well.

23. **Basket Rest:** Holds and tilts basket for draining when removing cooked product from oil or loading uncooked product.

CAUTION DO NOT rest basket on top flange of cooking well. Damage to area in contact with O-ring can cause leaking under pressure or O-ring failure.

6 - 1600 MECHANICAL CONTROL PANEL

FAMILIARIZATION

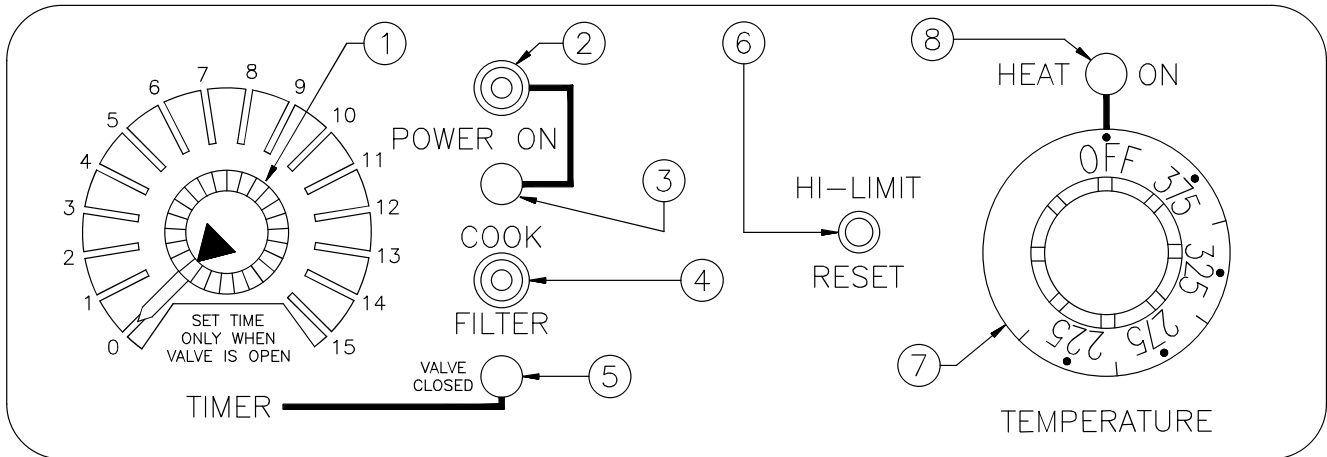

1. **Timer:** Outer dial indicates desired cooking time. Inner pointer indicates time countdown during a cook cycle.
2. **Power Switch:** Upper position allows use of the functions shown by cook/filter switch. Lower position is off.
3. **Power On Indicator Light:** Illuminates when power switch is in upper position.
4. **Cook/Filter Switch:** Has two positions: COOK and FILTER.
5. **Valve Closed Indicator Light:** Illuminates when pressure regulating valve is CLOSED.

6. **Hi-Limit Control:** Prevents oil temperature from exceeding 475°F. Turn unit **OFF** and **DO NOT** attempt to operate unit until it has been serviced by an authorized Broaster Company representative.

NOTICE It is possible for this control to trip during shipment. If it does, fully depress red reset button. If control “clicks” it was tripped. If not, it is correctly reset.

7. **Temperature Control:** Regulates oil temperature.
8. **Heat On Indicator Light:** Illuminates when oil is being heated.

New Mechanical Control Panel

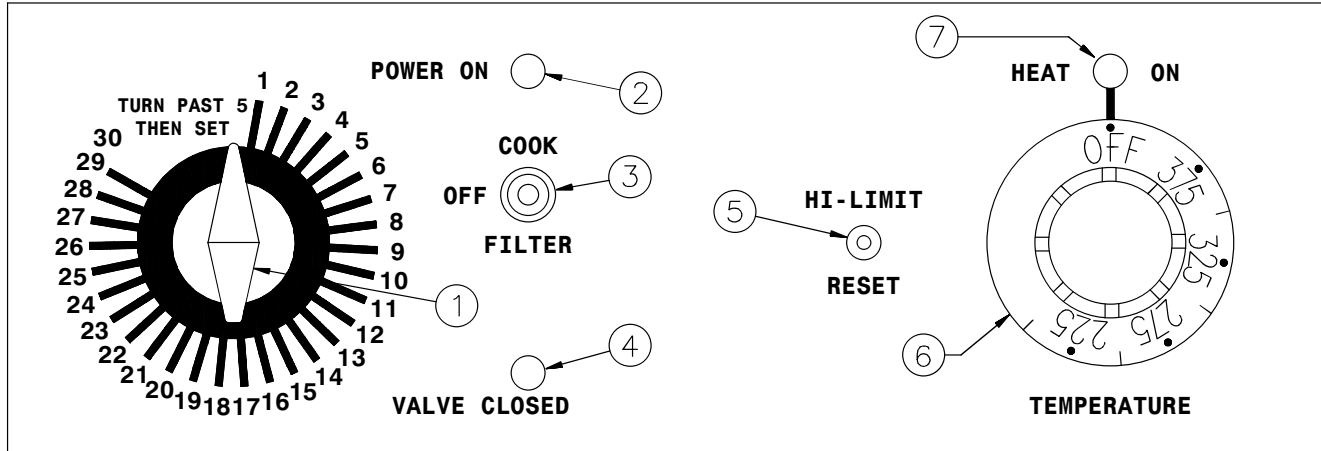

- 1. Timer:** Set to desired cooking time. Pointer indicates time countdown during a cook cycle.
- 2. Power On Indicator Light:** Illuminates when Cook/Filter switch is in upper position.
- 3. Cook/Filter Switch:** Has two positions, COOK and FILTER.
- 4. Valve Closed Indicator Light:** Illuminates when pressure regulating valve is CLOSED.

- 5. Hi-Limit Control:** Prevents oil temperature from exceeding 475°F. Turn unit **OFF** and **DO NOT** attempt to operate unit until it has been serviced by an authorized Broaster Company representative.

NOTICE

It is possible for this control to trip during shipment. If it does, fully depress red reset button. If control "clicks" it was tripped. If not, it is correctly reset.

- 6. Temperature Control:** Regulates oil temperature.
- 7. Heat On Indicator Light:** Illuminates when oil is being heated.

7 - SOLID STATE CONTROL PANEL

ROTARY DIAL FAMILIARIZATION

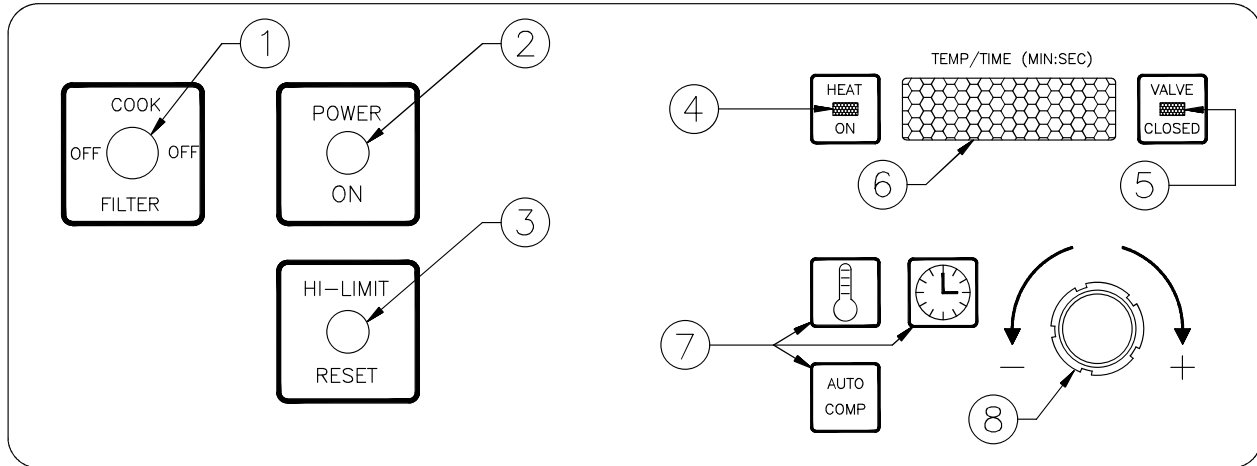

- 1. Cook/Filter Switch:** Has three positions: COOK, OFF and FILTER.
- 2. Power On indicator Light:** Illuminates when cook/filter switch is in COOK position.
- 3. Hi-Limit Control:** Prevents oil temperature from exceeding 475°F. Turn unit **OFF** and **DO NOT** attempt to operate until it has been serviced by an authorized Broaster Company representative.

NOTICE It is possible for this control to trip during shipment. If it does, fully depress red reset button. If control “clicks” it was tripped. If not, it is correctly reset.

- 4. Heat On Indicator Light:** Illuminates when oil is being heated.
- 5. Valve Closed Indicator Light:** Illuminates when pressure regulating valve is CLOSED.

- 6. Display:** Shows time countdown during a cook cycle, program values during programming and programmed time and temperature during idle period.
- 7. Program Buttons:** Displays program values, initiates programming, stores desired program values and exits programming mode.

Cook Temperature Button

Cook Time Button

AUTO COMP (Automatic Time Compensation) Button: Indicates timing method. When OFF, controller operates as a regular timer. When ON, controller monitors oil temperature and adjusts time to compensate for fluctuations in the oil temperature.

- 8. Rotary Knob:** Changes program values.

CONTROLLER PROGRAMMING



Check oil level before turning cook/filter switch to COOK.

Action: Turn cook/filter switch to COOK.

Response: Display alternates between number values for cook temperature, cook time and LO (idle mode). LO will disappear when oil temperature has reached cook temperature value.

Action: Press one of three buttons once.

Response: Display reads programmed value of button pressed. Display will return to idle mode after five seconds.

Set Temperature:

Action: Press cook temperature button twice within one second.

Response: Programming mode has been entered. Flashing display reads "###F." (### = temperature value ie: 360°F)

Action: If desired, turn rotary knob to change displayed value. Press cook temperature button to enter new value into memory.

Response: Controller returns to idle mode.

Set Time:

Action: Press cook time button twice within one second.

Response: Programming mode has been entered. Flashing display reads "##:##." (##:## = time value ie: 08:00)

Action: If desired, turn rotary knob to change displayed value in fifteen second increments. Press cook time button to enter new value into memory.

Response: Controller returns to idle mode.

Set AUTO COMP (Automatic Time Compensation):

Action: Press AUTO COMP button twice within one second.

Response: Programming mode has been entered. Flashing display reads ON or OFF.

Action: If desired, turn rotary knob to change displayed value. Press AUTO COMP button to enter new value into memory.

Response: Controller returns to idle mode.

DUAL DISPLAY FAMILIARIZATION

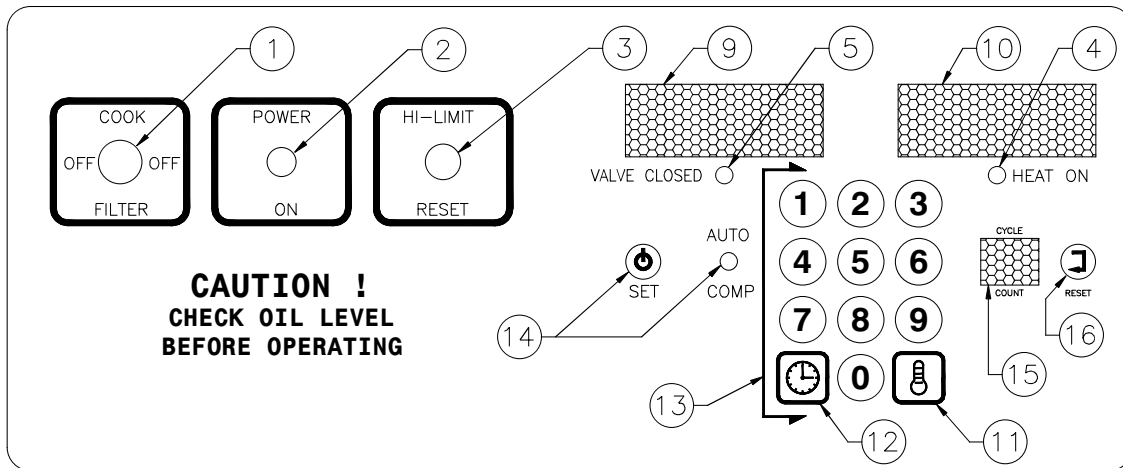

1. **Cook/Filter Switch:** Has three positions; COOK, OFF and FILTER.
2. **Power On indicator Light:** Illuminates when cook/filter switch is in COOK position.
3. **Hi-Limit Control:** Prevents oil temperature from exceeding 475°F. Turn unit **OFF** and **DO NOT** attempt to operate until it has been serviced by an authorized Broaster Company representative.

NOTICE It is possible for this control to trip during shipment. If it does, fully depress red reset button. If control “clicks” it was tripped. If not, it is correctly reset.

4. **Heat On Indicator Light:** Illuminates when oil is being heated.
5. **Valve Closed Indicator Light:** Illuminates when pressure regulating valve is CLOSED.
9. **Time Display:** Shows time count-down during a cook cycle, program values during programming and programmed time during idle period.

10. **Temp Display:** Shows set temperature and actual temperature on demand.
11. **Cook Temperature Button:** Initiates temperature programming and display actual temperature.
12. **Cook Time Button:** Initiates time programming.
13. **Numerical Keypad:** Enters and adjusts set point values.
14. **AUTO COMP (Automatic Time Compensation) Set Button and Light:** Indicates timing method. When OFF, controller operates as a regular timer. When ON, controller monitors oil temperature and adjusts time to compensate for fluctuations in the oil temperature.
15. **Cycle Count Display:** Increases in increments of one every time a cooking cycle is completed.
16. **Cycle Count Reset Button:** Resets the cycle count display to “zero”.

CONTROLLER PROGRAMMING



Check oil level before turning cook/filter switch to COOK.

Action: Turn cook/filter switch to COOK.

Response: Temp Display alternates between number values for cook temperature, and LO (idle mode). LO will disappear when oil temperature has reached cook temperature value. Time Display will show the set time in minutes and seconds.

Set Temperature:

Action: Press Cook Temperature Button twice within 5 seconds.

Response: Programming mode has been entered. Flashing Temp Display reads “###F.” (### = temperature value ie: 360F)

Action: If desired, press keypad numbers to change displayed value. Press Cook Temperature Button to enter new value into memory.

Response: Controller returns to idle mode.

Set Time:

Action: Press Cook Time Button twice within 5 seconds.

Response: Programming mode has been entered. Flashing Time Display reads “##:##.” (##:## = time value ie: 08:00)

Action: If desired, press key pad numbers to change displayed value in minutes and seconds. Press Cook Time Button to enter new value into memory.

Response: Controller returns to idle mode.

Set AUTO COMP (Automatic Time Compensation):

Action: Press and hold AUTO COMP Button for 3 seconds.

Response: Green light will toggle on or off.

Read Actual Temperature:

Action: Press and hold Temp Button for 3 seconds.

Response: Temp Display will show actual oil temperature and will vary as cooling and heating takes place.

Action: Press Temp Button to return to set point display.

Reset Cycle Counter:

Action: Press Reset Button twice in 5 seconds.

Response: Display will return to a setting of “00.”

NOTICE

If counter is not reset before reaching “99.”

Upon the next cycle completion, the display will begin counting at “01.”

TEMP-N-TIME FAMILIARIZATION

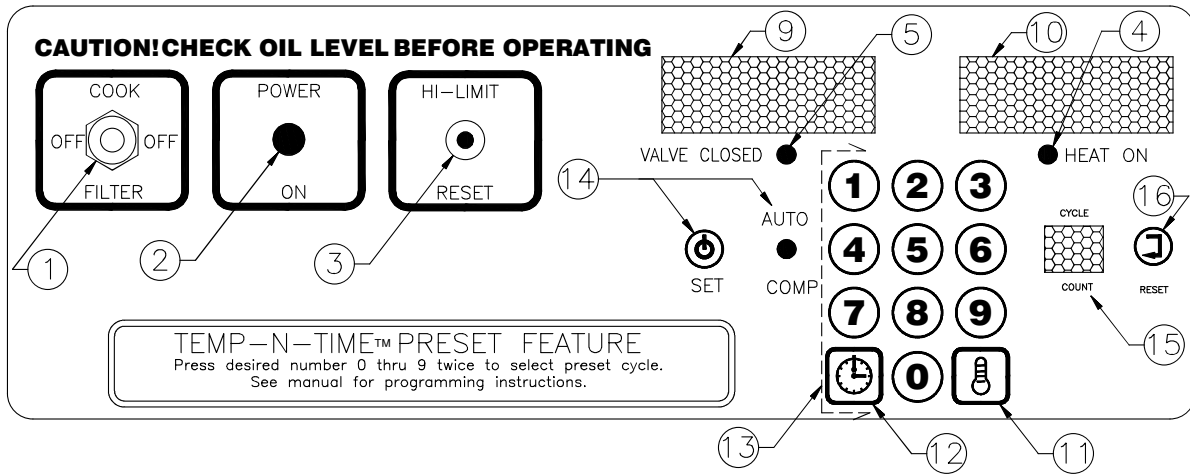

1. **Cook/Filter Switch:** Has three positions: COOK, OFF and FILTER.
2. **Power On indicator Light:** Illuminates when cook/filter switch is in COOK position.
3. **Hi-Limit Control:** Prevents oil temperature from exceeding 475°F. If power to unit turns off due to Hi-Limit Control, turn unit **OFF** and **DO NOT** attempt to operate until it has been serviced by an authorized Broaster Company representative.

NOTICE It is possible for this control to trip during shipment. If it does, fully depress red reset button. If control “clicks” it was tripped. If not, it is correctly reset.

4. **Heat On Indicator Light:** Illuminates when oil is being heated.
5. **Valve Closed Indicator Light:** Illuminates when pressure regulating valve is CLOSED.
6. **Time Display:** Shows time count-down during a cook cycle, program values during programming and programmed time during idle period.

7. **Temp Display:** Shows set temperature and actual temperature on demand.
8. **Cook Temperature Button:** Initiates temperature programming and display actual temperature.
9. **Cook Time Button:** Initiates time programming.
10. **Numerical Keypad:** Enters and adjusts set point values.
11. **AUTO COMP (Automatic Time Compensation) Set Button and Light:** Indicates timing method. When OFF, controller operates as a regular timer. When ON, controller monitors oil temperature and adjusts time to compensate for fluctuations in the oil temperature.
12. **Cycle Count Display:** Increases in increments of one every time a cooking cycle is completed.
13. **Cycle Count Reset Button:** Resets the cycle count display to “zero”.

CONTROLLER BASIC PROGRAMMING

NORMAL OPERATING MODE

CAUTION

Check oil level before turning cook/filter switch to COOK.

Action: Turn cook/filter switch to COOK.

Response: Temp Display alternates between number values for cook temperature, and LO (idle mode). LO will disappear when oil temperature has reached cook temperature value. Time Display will show the set time in minutes and seconds.

Set Temperature:

Action: Press Cook Temperature Button twice within 5 seconds.

Response: Programming mode has been entered. Flashing Temp Display reads “###F.” (### = temperature value ie: 360F)

Action: If desired, press keypad numbers to change displayed value. Press Cook Temperature Button once to enter new value into memory.

Response: Controller returns to idle mode.

Set Time:

Action: Press Cook Time Button twice within 5 seconds.

Response: Programming mode has been entered. Flashing Time Display reads “##:##.” (##:## = time value ie: 08:00)

Action: If desired, press key pad numbers to change displayed value in minutes and seconds. Press Cook Time Button once to enter new value into memory.

Response: Controller returns to idle mode.

Set AUTO COMP (Automatic Time Compensation):

Action: Press and hold AUTO COMP Button for 3 seconds.

Response: Green light will toggle on or off.

Reset Cycle Counter:

Action: Press Reset Button twice in 5 seconds.

Response: Display will return to a setting of “00.”

NOTICE

If counter is not reset before reaching “99.”

Upon the next cycle completion, the display will begin counting at “01.”

Normal operating programming can be done at any time without affecting presets.

PRESET COOK MODE PROGRAMMING

PROGRAMMING METHOD 1

For fryers manufactured Aug 2016 or later.

Select the temperature and time, following the normal programming procedure. To save these settings for a preset. Press and hold the desired preset number for five seconds until an audible beep is sounded.

PROGRAMMING METHOD 2

For fryers manufactured before Aug 2016

Choose Preset Cook Cycle:

Action: Press a button, 0 thru 9, corresponding to the desired preset.

Response: The TIME display will show "P__X", where X is the preset selected.

NOTICE If a button is not pressed in ten seconds, the display will revert to the previous display.

Action: Press the same button again,

Response: The TIME display will show the preset time, the AUTO COMP LED will turn on if enabled, the TEMP display will show the preset setpoint, and the temperature will now regulate to the new setpoint.

PROGRAMMING PROCEDURE (PRESET MODE)

Action: Press and hold the TIME and TEMP buttons simultaneously for three seconds.

Response: The TIME display and TEMP display will begin flashing. The CYCLE COUNT display will show "-0" indicating that the preset #0 values are displayed. The preset values for the TIME, TEMP, and AUTO COMP will be shown on the display.

Change Cook Time:

Action: Press the TIME button once.

Response: The TEMP display will turn off and only the TIME display will flash.

Action: Key in the desired cook time and press the TIME button to save the new setting.

NOTICE If a button is not pressed in ten seconds, the display will revert back to both the TIME and TEMP displays flashing.

Change Cook Temperature:

Action: Press the TEMP button once.

Response: The TIME display will turn off and the TEMP display will be flashing.

Action: Key in the desired temperature setting and press the TEMP button to save the new setting.

NOTICE If a button is not pressed in ten seconds, the display will revert back to both the TIME and TEMP displays flashing.

Activate/Deactivate Auto Comp:

Action: Press and hold the AUTO COMP button for 3 seconds.

Response: AUTO COMP is enabled when the AUTO COMP LED is on and disabled when it is off.

Advance to Next Preset:

Action: Press the RESET button once.

Response: The CYCLE COUNT display will change to “-1” and the presets for #1 will be displayed.

Repeat the process as described. After the presets for #9 are displayed, pressing the RESET button again will cause the control to return to normal operation.

SMART TOUCH FAMILIARIZATION

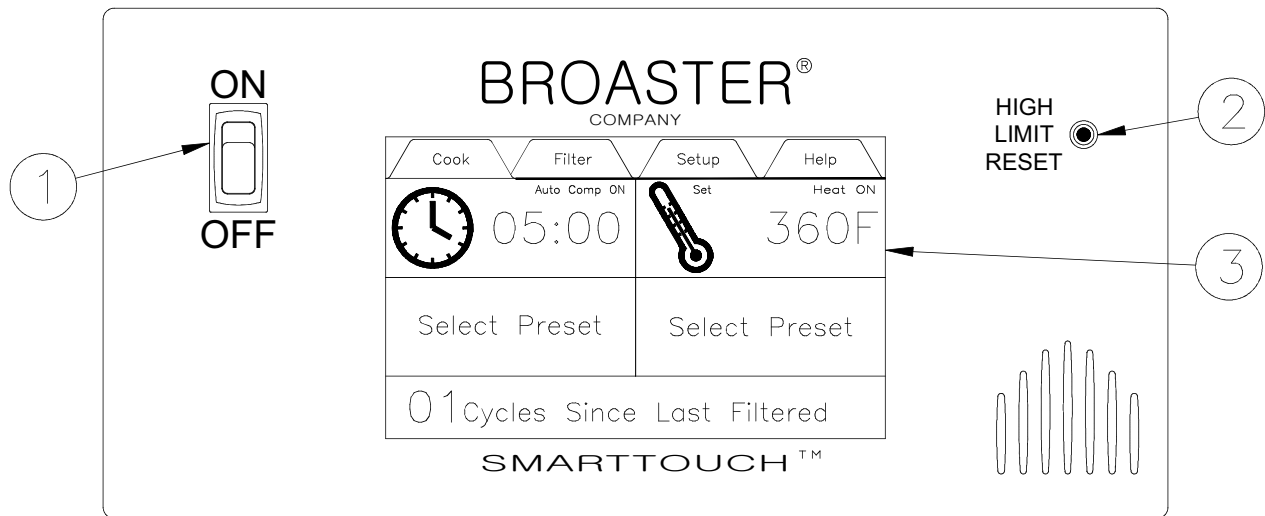

1. **Power Switch:** This switch has two positions: ON or OFF.

2. **Hi-Limit Control:** Prevents oil temperature from exceeding 475°F. When this control trips, the power to the unit will be shut down. Turn unit OFF and DO NOT attempt to operate until it has been serviced by an authorized Broaster Company representative.

NOTICE It is possible for this control to trip during shipment. If it does, fully depress red reset button. If control “clicks” it was tripped. If not, it is correctly reset.

3. **Touch Control Screen:** Touching this screen controls the many options of the fryer.

On initial power up you may be asked to enter the current date and time, and verify the Serial Number. Or the screen will have the word CAUTION flashing on the screen.

If the date and time entry screen appears press the box after “Month” and a keypad will appear. Enter the number of the month and press the enter key. Repeat this action for the Day, Year, Hours, Minutes, Seconds, AM and PM boxes. When finished press the

green OK button in the bottom right corner of the screen. The next display will ask you if this date should be used to establish the warranty start date. Press the green OK button.

You will then see a display asking you to verify the serial number of your fryer. Enter the serial number using the keyboard and press enter.

NOTICE The date/time display and the serial number display will not appear again when the power switch is turned off and back on.

A CAUTION screen will appear to remind you to check the oil level before the heating elements or burner are activated. If the oil is at the proper level, press the green OK button in the bottom right corner of the screen.

Along the top of the screen are four tabs (Cook, Filter, Setup and Help) to help you setup and use your fryer.

COOK TAB

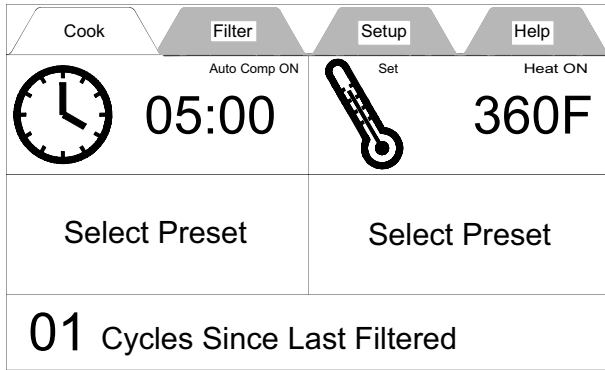

This tab is the main working screen. From this screen you can set the Cook Cycle Time, Cook Temperature, or select a Product Preset.

CookTime Display:



The cook time is indicated in the box next to the clock face. To change the time press the time display twice and a keypad will appear.

Enter the cook time for the product you are cooking, as you enter the time it will appear above the keypad. To save this time press the enter key the new time will be entered and the keypad will disappear.

If no entry is made or the enter key is not pressed within 25 seconds, no change is made to the time.

When a cooking cycle is started the box below the cook time turns yellow and shows the amount of time remaining in the cycle. The right box displays "CUSTOM". The word "CUSTOM" also replaces the tabs across the top of the display. "CUSTOM" indicates you are in manual cooking mode.

At the end of the cycle the left box alternates between red and white, the alert sounds and continues until the exhaust valve is opened by turning the small handle on the countertop from "CLOSED" to "OPEN".

Auto Comp

In the upper right corner of the cook time display is the Auto Comp indicator. It will be black if Auto Comp is off and green if Auto-Comp is on.

To turn Auto Comp on or off press the cook time display twice. When the keypad appears the Auto Comp toggle switch is in the upper right corner of the keypad. If the button is red Auto Comp is off, if it is green Auto Comp is on. Press the Auto Comp button to change it then press the enter key.

Our recommendation is that Auto Comp should be on when cooking a load of product.

Temperature Display:

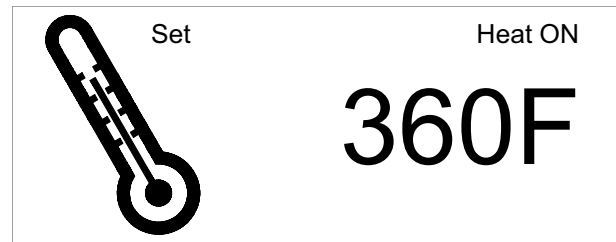

The temperature is indicated next to the thermometer.

When the fryer is turned on in the morning this box will be yellow and "Heat On" will be displayed. The temperature will alternate between "LOW" and the set temperature until the oil temperature reaches the set temperature.

There are other times when this will occur;

1. Anytime the temperature is changed.
2. After a filtering cycle.
3. When a preset is selected and the oil temperature is not at the preset temperature.

In any of these cases when the oil temperature reaches the set temperature the box turns green indicating the oil is up to the set temperature.

The temperature shown in this box can be either the “Set” temperature or the “Actual” temperature as indicated above the thermometer. To change from one to the other press anywhere in the box for 3 seconds. An alert will sound when you press the box and a second alert will sound when the change is made.

To set the temperature, press the temperature box twice and a keypad will appear. Enter the temperature for the product you want to cook, as you enter the temperature, it will appear above the keypad. To save this temperature press the enter key.

Select Preset Display:



There are 2 “Select Preset” boxes.

All of Broaster Company’s products are pre-loaded into the memory of the control and can be selected when you want to cook that product. The cook time and cook temperature for that product will be automatically entered in the Time and Temperature displays.

To select a product, press either preset box and a menu of the products will be displayed. Tap the product you wish to select.

If the wrong product comes up, don’t worry! Tap the preset box again and the menu will reappear.

When the item has been selected a picture of the item will appear in the left box and a description of the item will appear in the right box. When a cook cycle is started the left box turns yellow and the time remaining in the cycle is displayed. The picture moves to the right box.

If the menu item to be cooked uses a different temperature the temperature box will either remain green meaning it is all right to start a cook cycle or it will turn yellow meaning the temperature is too low to start a load. Wait to start a cook cycle until the temperature is green.

When the temperature is green. Load the product as recommended and move the small handle on the top of the fryer from open to close. This will start the cycle timer counting down. When the load is done an alert will signal that the cooking cycle is complete.

Cycles Since Last Filtered:



It is recommended the oil should be filtered every 5 loads.

This box indicates how many cook cycles have been completed since the last time the oil was filtered. It is active and can be pressed at any time to go to the filter display except during a cooking cycle. Once you reach a preset number of cycles, you will be shown a filter options screen. If a filter cycle is bypassed the next cycle will turn red and start flashing.

This number can be changed and the procedure will be explained in the Setup Tab section.

FILTER TAB

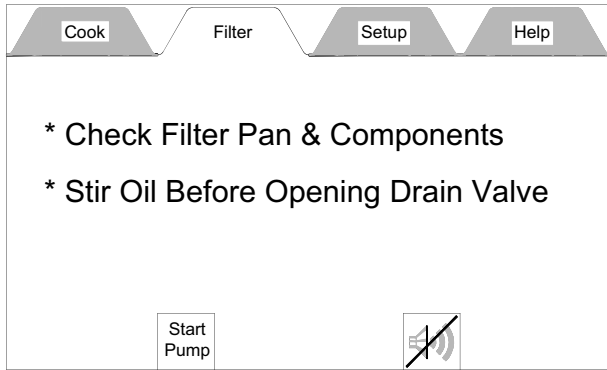

This tab is the filter motor control and has two buttons; a Start Pump button and a Silence Alert button.

There are also two reminders to observe before filtering the oil. SEE SECTION 9 - COOKING OIL CARE AND FILTERING before starting the pump motor.

When the Start Pump button is pressed the filter running display appears as shown below.



The timer in the middle of the screen starts counting up. When it reaches 5:00 minutes an alert sounds and a reminder flashes (see below) to close the drain valve. To silence the alert press the button with the speaker on it. DO NOT press the Stop Pump button.

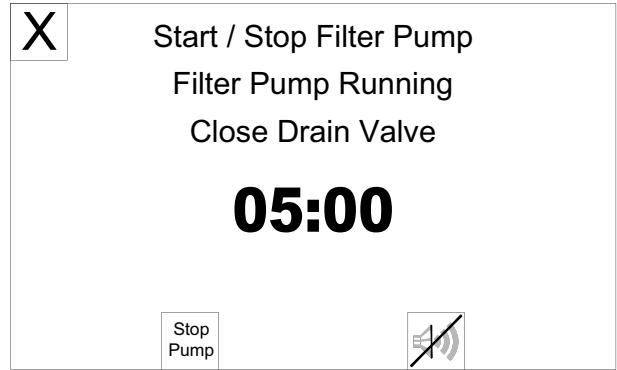

Press STOP PUMP after the oil is completely returned to the cooking well or you can leave the pump running and it will automatically stop when the counter says 10:00 minutes. See display below.

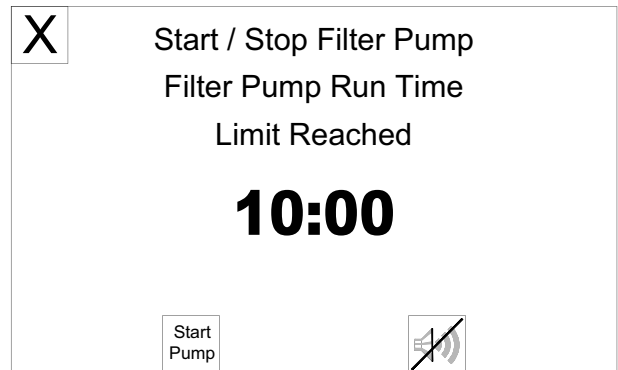

To return to the Cook Tab, press the red X in the upper left corner. The Caution Display will appear advising the oil level be checked. If the oil level is OK press the green OK button.

SETUP TAB

This tab may or may not be secured. If it is unsecured the Pin Disabled display will appear as shown below. Press the OK button to continue.

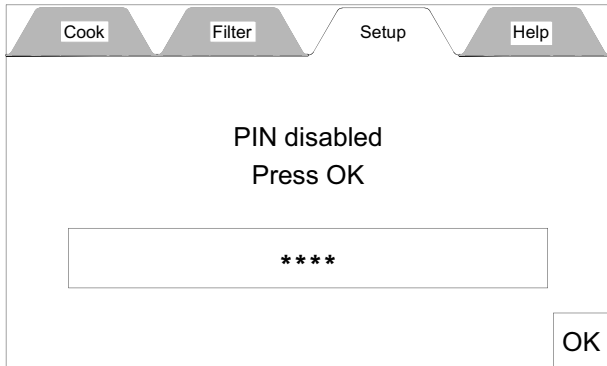

If this tab is secured the Enter Pin display will appear as shown below.

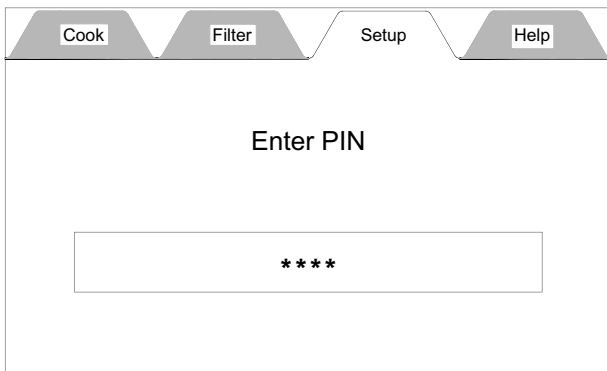

If the Pin number is known, press the box and a keypad will appear. Enter the PIN number and press Enter.

Setup Display:

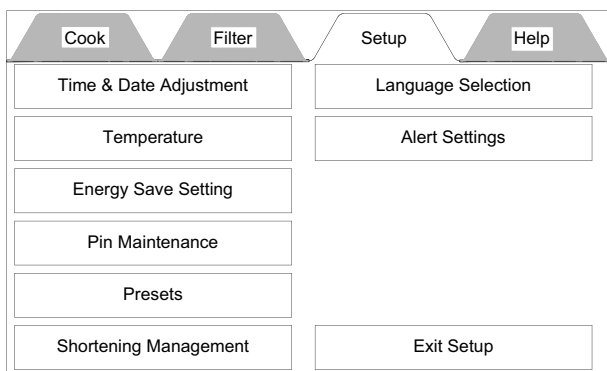

Time & Date Adjustment:

Pressing this option opens the Set Date & Time display.

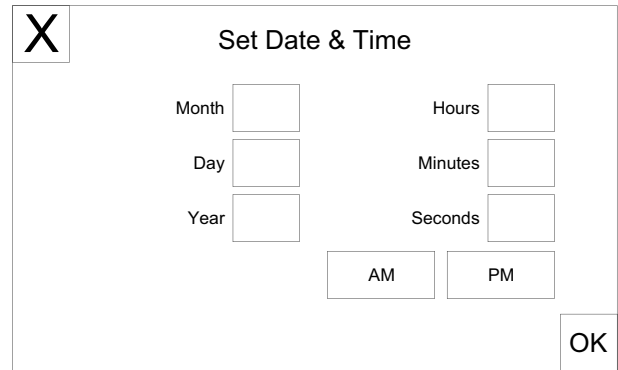

To set the date and time, press the box after “Month” and a keypad will appear. Enter the number of the month and press the enter key. Repeat this action for the Day, Year, Hours, Minutes, Seconds, AM and PM boxes. When finished press the green OK button. To leave this display without making a change press the red X or the green OK.

Temperature:

Pressing this option opens the Temperature Settings Display.

The only thing that can be set in this display is the temperature scale, either Degrees F (Fahrenheit) or Degrees C (Celsius).

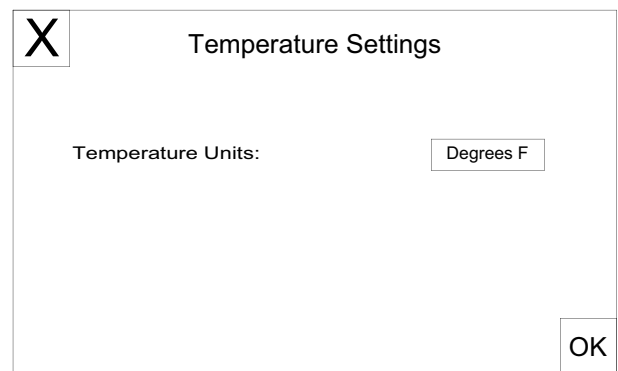

Pressing the Degrees box switches the units.

Energy Save Setting:

Pressing this option opens the Energy Saving Settings display.

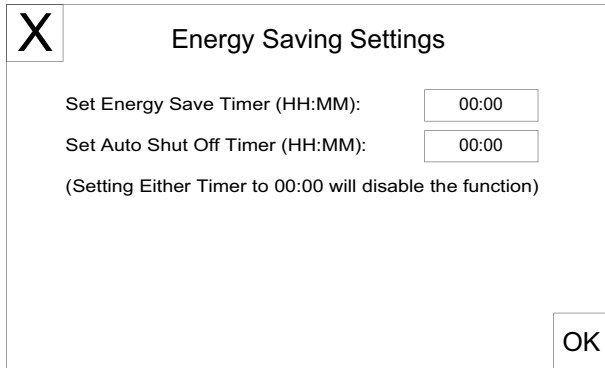

The screen displays the title "Energy Saving Settings" with a close button (X) in the top left. It contains two input fields: "Set Energy Save Timer (HH:MM):" with a value of "00:00" and "Set Auto Shut Off Timer (HH:MM):" with a value of "00:00". Below these is a note: "(Setting Either Timer to 00:00 will disable the function)". An "OK" button is located in the bottom right corner.

You have two options on this display:

OPTION 1: Energy Saving Option.

The fryer will go into this mode when the specified idle time has passed. When the fryer goes into the energy saving mode the oil temperature will drop to 270° F (132° C) and remain there until the fryer is prompted by pressing the green OK button, to resume the normal cooking temperature. When the fryer enters the energy saving mode the display shown below appears.

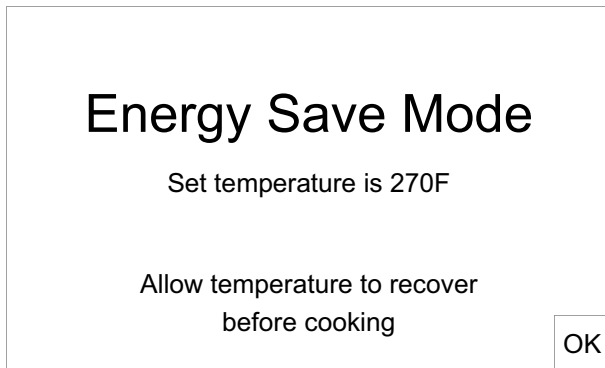

The screen displays the title "Energy Save Mode". Below the title, it says "Set temperature is 270F". Further down, it says "Allow temperature to recover before cooking". An "OK" button is located in the bottom right corner.

When the OK button is pressed the display returns to the normal Cook Tab display and the temperature will be yellow and Low and the set temp will be alternating. **DO NOT** start cooking until the temp display is green.

Option 2: Auto Shut Off Timer.

When this option is set, the control will shut off all heaters after the specified time, and the display shown below will appear.



The screen displays the title "Heat Off" in large font. Below it, it says "due to inactivity". Further down, it says "Hit 'OK' to resume and allow temperature to recover before cooking". An "OK" button is located in the bottom right corner.

Follow the instructions on the screen to resume use of the fryer.

For either of these options set the desired time by pressing the time button. A keypad will appear. Enter the desired time. As you enter the hours and minutes they will appear above the keypad. When the time is entered press the green OK button.

Pin Maintenance:

Pressing this option opens the PIN Maintenance display.

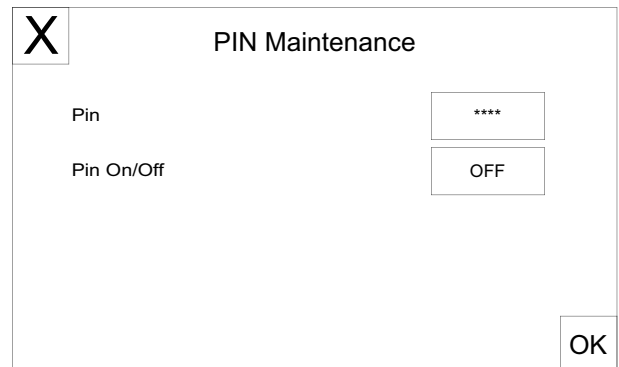

The screen displays the title "PIN Maintenance" with a close button (X) in the top left. It contains two input fields: "Pin" with a value of "****" and "Pin On/Off" with a value of "OFF". An "OK" button is located in the bottom right corner.

Presets:

Pressing this option opens a list of products with a picture of the product and the cook time and cook temperature pre-loaded.

This is where the product preset is either shown or not shown as a preset on the Cook Tab.

Select Preset or	Add New	Load Menu	Export Menu
# 1	<input type="checkbox"/>	Chicken 8pc Mixed FRESH	
# 2	<input type="checkbox"/>	Chicken Popcorn Cajun IQF	
# 3	<input type="checkbox"/>	Chicken Popcorn Regular IQF	
# 4	<input type="checkbox"/>	Chicken Tenders Home Style IQF	
# 5	<input type="checkbox"/>	Chicken Tenders Regular IQF	
# 6	<input type="checkbox"/>	Burrito Bean'n Beef IQF	
# 7	<input type="checkbox"/>	Burrito Breakfast IQF	
# 8	<input type="checkbox"/>	Burrito Pizza IQF	

By default all products will be shown. To turn any product off, press the item once and the Edit/Create Preset display will appear.

Stage	Temperature	Time	Comp On / Off	Active
1	360F	05:00	On	Yes
2	000F	00:00		
3	000F	00:00		

OK

Here you can edit the name of the of the product, change its position on the list, set the cook time and temperature, set Auto Comp to be on or off during the cooking cycle and whether or not this item should be active as a preset on the Cook Tab..

Creating a new product or deleting a product on the list will be described later.

Name Edit:

To edit the name of the current product press the Edit / Enter Preset Name bar and a typewriter keyboard will appear. The cursor will be at the end of the name. To change the name press the BACK button and the cursor will delete the name one letter each time the BACK button is pressed.

Delete the letters until you get to the place where you want to start making the change. To get the numbers and symbols to come up press the Symbol key.

When you have completed entering the changed name press the ENTER key.

Position Edit:

To change the position of this item on the menu list, press the Edit / Enter Preset Number bar and a number pad will appear. Enter the number of the position you want this item to appear at then press the ENTER key.

Time & Temperature Edit:

Most of the cooking will be done on stage 1. To edit this feature press the button and a number pad will appear. Enter the desired cooking temperature or time and press the ENTER button. If a number is entered and the ENTRY button is not pressed within 30 seconds the number pad will disappear and no changes will be saved.

Comp On / Off:

This button toggles Auto Comp on or off.

Active:

This button allows the item to be shown in the preset menu list of the Cook Tab. If the button says Yes the item appears on the list if No it does not.

You can quickly tell when a product is not active because the name and number of the item will be greyed out.

ADD NEW:

Pressing this button opens a display to enter a new product to the menu list. This display is similar to the Edit display except all information must be added.

Stage	Temperature	Time	Comp On / Off	Active
1	000F	00:00	On	Yes
2	000F	00:00		
3	000F	00:00		

To enter the name press the Edit / Enter Preset Name bar and enter the name of the new product.

The Preset Number automatically defaults to the next number after the last item on the list. This can be changed by pressing the Edit / Enter Preset Number bar and entering the number where you want this item to appear.

Set the cook temperature and cook time the same way as when editing a preset.

Set Auto Comp and Activity accordingly.

Press the green OK button to save the new product.

Menu Transfer:

The Smart Touch control allows a revised menu to be transported from one fryer to other fryers which also have a Smart Touch control. This is done from the Preset tab using the Load Menu and Export Menu buttons along the top of the display.

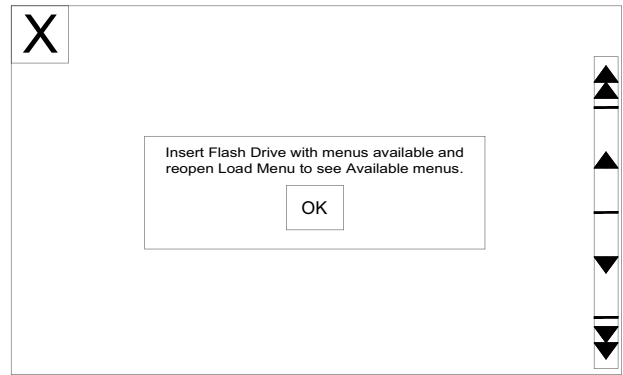

EXPORT MENU:

When you make changes to the menu on one fryer and want to put the same menu on other fryers with the Smart Touch Control you can export the revised menu from this fryer to the flash drive and load it onto the other fryers.

Plug the flash drive into the USB port in the front panel above the control panel. Press the Export Menu button on the Preset menu display.

Press the Export Menu button once and the control will ask you for a filename. Press the Enter Menu File Name bar and a keyboard will appear. Enter a name you will recognize then press the ENTER Button.

NOTICE

The file name can only be 8 characters long.

When the ENTER key is pressed a box will appear that says Exporting Menu... with a progress bar.

When the export is complete the box will say "Menu Exported". Press the OK button and the Preset display will appear. Remove the flash drive from the USB port.

LOAD MENU:

Menu changes that have been downloaded to a flash drive can be loaded onto fryer.

Plug the flash drive into the USB port in the front panel above the control panel. Press the Load Menu button on the Preset menu display.

When the display appears there may be more than one menu. Press the bar for the menu you want loaded and a “Loading Menu...” box will appear with a progress bar.

When the menu is loaded a box will appear saying “Menu Loaded”. Press the OK button and the Preset display will appear.

Remove the flash drive from the USB port.

SHORTENING MANAGEMENT:

Pressing this option opens the Shortening Management Display.

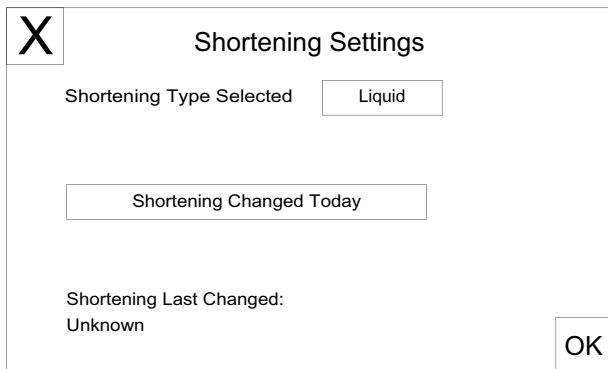

Pressing the button next to Shorting Type toggles between “Liquid” and “Solid”.

Selecting “SOLID” activates a melt cycle when the controller is turned on and the oil temperature is below 200° F.

Pressing the “Shortening Changed Today” bar enters today’s date and time as a reminder when the oil was last changed. this also resets the “Cycles Since Last Filtered” counter to 00 on the Cook Tab.

LANGUAGE SELECTION:

Pressing this option will allow you to change the language used in all displays.

ALERT SETTINGS:

Pressing this option allows you to set conditions for several features.

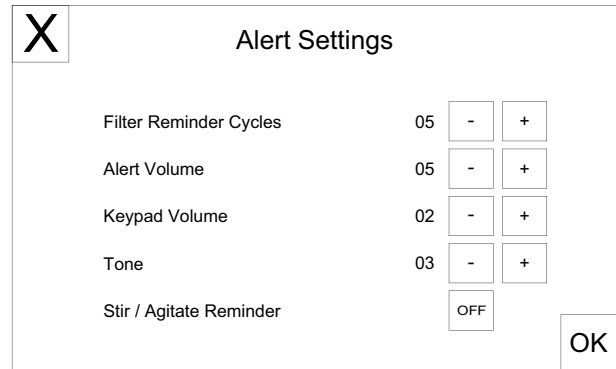

The numbers left of the boxes indicate the current setting. They can be changed by pressing the “-” or “+” buttons.

Filter Reminder Cycles: This sets the number of cook cycles between each oil filter cycle. The Broaster Company recommends 5 cook cycles however, you can set it as you desire. A setting of “0” will disable the filter reminder screen.

Alert Volume: This should be set loud enough to be able to hear it above any other noises in the kitchen.

Keypad Volume: It should be loud enough to hear while making changes in front of the fryer or when operating the fryer.

Tone: There are a range of tones from low to very high. Chose the one that suits your operation.

Stir/Agitate Reminder: This alert appears when 3 conditions occur.

1. When the fryer is first turned on in the morning, this reminder will appear after the oil comes up to the set temperature.
2. After a filter cycle has been completed this reminder will appear after the oil comes up to the set temperature.
3. If the fryers has been setting idle for 2 hours or longer this reminder will appear to alert you to stir the oil to get it to a uniform temperature.

After making the adjustments on this display press the green OK button to save the entries.

To go back to the Cook display either press the “Exit Setup” button or the Cook Tab.

HELP TAB

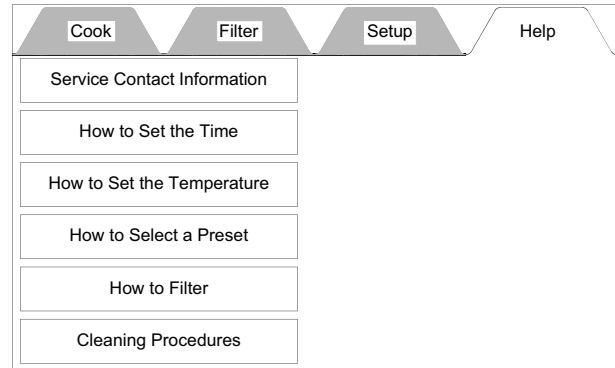

This display provides instructions for the items in the boxes. They are available at any time to help you set up the control to cook product.

TOUCHSCREEN CALIBRATION

If the buttons on the screen are not responding as expected, the following procedure will recalibrate the touchscreen: With the unit off, place fingertip in the middle of the screen and hold it there while turning unit on.

Remove finger when “**CALIBRATE TOUCHSCREEN**” appears in the upper left corner of the screen. Locate the small red box in the upper left corner and press it once, the box will move to another corner. Press it again to move it again, then press it one more time. The controller will now boot up normally, and the touchscreen will now be in proper calibration.

8 - COOKING WEIGHT, TEMPERATURE AND TIME

FRESH PRODUCTS

⚠ WARNING ALWAYS COOK ALL BROASTER PRODUCTS UNTIL THE INTERNAL TEMPERATURE REACHES THE FOLLOWING MINIMUMS:

Chicken, White - 170°F;
Chicken, Dark - 180°F;
Corn Dogs/Pork - 160 to 170°F;
Fish - 155°F

The charts below give suggested temperature and time settings. Actual cook times may vary depending on a product's internal temperature before cooking. Times indicated below assumes AutoComp is ON.

NOTICE

Increase cook time when cooking frozen or oversized product.

Use our methods of food preparation and cooking procedures for the best possible results.

MAXIMUM LOAD:

Fresh bone-in chicken

1600: 3.2 Kg (7 lbs.)

1800: 6.4 Kg (14 lbs)

⚠ WARNING

Placing more than the recommended weight of fresh product or product that is over-wet in the cooking basket will increase the amount of surge boiling in the cooking well.

PRODUCT	WEIGHT/THICKNESS	TEMPERATURE	TIME
Fresh Chicken 8 or 9 Piece Cut	0.90 - 1.02 Kgs (2.00 - 2.25 lbs.)	182° C (360° F)	7:15 - 7:45 min.
	1.02 - 1.13 Kgs (2.25 - 2.50 lbs.)	182° C (360° F)	7:45 - 8:15 min.
	1.13 - 1.25 Kgs (2.50 - 2.75 lbs.)	182° C (360° F)	8:15 - 9:00 min.
	1.25 - 1.36 Kgs (2.75 - 3.00 lbs.)	182° C (360° F)	9:00 - 9:30 min.
	1.36 - 1.47 Kgs (3.00 - 3.25 lbs.)	182° C (360° F)	9:30 - 10:00 min.
	1.47 - 1.59 Kgs (3.25 - 3.50 lbs.)	182° C (360° F)	10:00 - 10:30 min.
Whole Chicken	1.02 - 1.13 Kgs (2.25 - 2.50 lbs.)	182° C (360° F)	12:00 - 13:00 min.
Potatoes	Quartered	182° C (360° F)	7:00 - 8:00 min.
Pork Ribs	0.90 Kgs (2.00 lbs.) and Under	182° C (360° F)	6:00 - 7:00 min.
Pork Chops	19.05 mm (3/4 In) Thick	182° C (360° F)	5:00 min.
Liver	6.35 mm (1/4 In) Thick	182° C (360° F)	1 1/2 min.
Fish	0.09 Kgs (3 oz.) Filets	182° C (360° F)	3:00 - 4:00 min.
Onion Rings	9.53 - 12.70 mm (3/8 - 1/2 In) Thick	182° C (360° F)	2:00 - 3:00 min.

INDIVIDUALLY QUICK FROZEN (IQF) CHICKEN, FROZEN

⚠ WARNING ALWAYS COOK ALL BROASTER RECIPE PRODUCTS UNTIL THE INTERNAL TEMPERATURE REACHES THE FOLLOWING MINIMUMS:

Chicken, White - 170°F;
 Chicken, Dark - 180°F;
 Corn Dogs/Pork - 160 to 170°F;
 Fish - 155°F

Keep uncooked product frozen at 0°F or below at all times.

Maximum Load Size:

- 1600: 2 chickens (16 pieces)
- 1800: 4 chickens (32 pieces)

PRODUCT	MAXIMUM LOAD	TEMPERATURE	TIME
Thighs	1600: 10 pieces. 1800: 20 pieces.	168° C (335° F)	15:00 - 17:00 min.
Legs	1600: 16 pieces. 1800: 32 pieces.	168° C (335° F)	15:00 - 17:00 min.
Breasts	1600: 8 pieces 1800: 16 pieces.	168° C (335° F)	17:00 - 19:00 min.
Wings	1600: 20 pieces. 1800: 40 pieces.	168° C (335° F)	12:00 - 14:00 min.
Mixed Load	1600: 16 pieces. 1800: 32 pieces.	168° C (335° F)	17:00 - 19:00 min.

1600 BROASTER RECIPE PRODUCTS COOKING CHART

All cook times are approximate and will vary depending on load size, etc.

Product Description	Package Description	Product Number	Lbs/Cas e	Cooking Time	Cooking Temperature	Approx. Load - Kgs (Lbs.)	
						MIN	MAX
Jumbo Popcorn Chicken	2/5# bags	96262	10	4 - 4.5 Min.	182°C (360°F)	.45 Kgs (1 lb.)	1.8 Kgs (4 lbs)
Cajun Jumbo Popcorn Chicken	2/5# bags	96277	10	4 - 4.5 Min.	182°C (360°F)	.45 Kgs (1 lb.)	1.8 Kgs (4 lbs)
Chicken Tenders	2/5# bags	96641	10	5 - 6 Min.	182°C (360°F)	.45 Kgs (1 lb.)	1.8 Kgs (4 lbs)
Zesty Home Style Chicken Tenders	2/5# bags	96349	10	5 - 6 Min.	182°C (360°F)	.45 Kgs (1 lb.)	1.8 Kgs (4 lbs)
Chicken Fillets	2/5# bags	96638	10	6 - 7 Min.	182°C (360°F)	.45 Kgs (1 lb.)	1.8 Kgs (4 lbs)
Traditional Wings	2/5# bags	96261	10	8 - 10 Min.	182°C (360°F)	.45 Kgs (1 lb.)	1.8 Kgs (4 lbs)
Hot 'N Spicy Wings	4/5# bags	96639	20	8 - 10 Min.	182°C (360°F)	.45 Kgs (1 lb.)	1.8 Kgs (4 lbs)
Boneless Buffalo Wings	2/5# bags	96318	10	5 - 6 Min.	182°C (360°F)	.45 Kgs (1 lb.)	1.8 Kgs (4 lbs)
Fully-Cooked Oven Roasted Chicken Wings	2/5# bags	96351	10	6 - 7 Min.	182°C (360°F)	.23 Kgs (0.5 lb.)	1.36 Kgs (3 lbs)
Chicken Gizzards	Bulk Packed	96271	10	4 - 6 Min.	182°C (360°F)	.45 Kgs (1 lb.)	1.8 Kgs (4 lbs)
Jumbo Corn Dogs	Bulk Packed	96661	10	Thawed 6 - 7 Min.	182°C (360°F)	.45 Kgs (1 lb.)	1.8 Kgs (4 lbs)
Jumbo Corn Dogs	Bulk Packed	96661	10	Thawed 7 - 8 Min.	168°C (335°F)	.45 Kgs (1 lbs.)	1.8 Kgs (4 lbs)
Jumbo Corn Dogs	Bulk Packed	96661	10	Frozen 13 - 14 Min.	168°C (335°F)	.45 Kgs (1 lbs.)	1.8 Kgs (4 lbs)
Pork Tenderloin	Bulk Packed	96313	9.75	3 - 3.5 Min.	182°C (360°F)	.45 Kgs (1 lbs.)	1.8 Kgs (4 lbs)
Deluxe Pizza Burritos	48 in 7 trays	96316	15	6.5 - 7.5 Min.	182°C (360°F)	.23 Kgs (0.5 lb.)	.68 Kgs (1.5 lbs)
Deluxe Beef 'n Bean Burritos	48 in 7 trays	96317	15	5.5 - 6.5 Min.	182°C (360°F)	.23 Kgs (0.5 lb.)	.68 Kgs (1.5 lbs)
Deluxe Breakfast Burritos	48 in 7 trays	96323	15	6.5 - 7.5 Min	182°C (360°F)	.23 Kgs (0.5 lb.)	.68 Kgs (1.5 lbs)
Catfish Tender Strips	Bulk Packed	96340	10	3.5 - 4 Min	182°C (360°F)	.45 Kgs (1 lbs.)	1.8 Kgs (4 lbs)
Hand-Breaded Style Catfish Fillets	Bulk Packed	96354	10	4 - 5 Min	182°C (360°F)	.45 Kgs (1 lbs.)	1.8 Kgs (4 lbs)
Premium Cod Fillets (2 oz. Natural Cut)	2/5# bags	96329	10	4 - 5 Min.	182°C (360°F)	.23 Kgs (0.5 lb.)	1.36 Kgs (3 lbs)
Premium Cod Fillets (4 oz. Natural Cut)	2/5# bags	96295	10	5 - 6 Min.	182°C (360°F)	.23 Kgs (0.5 lb.)	1.36 Kgs (3 lbs)
Premium Beer-Battered Recipe Shrimp (tail-off)	Bulk Packed	96286	8	2.5 - 3 Min.	182°C (360°F)	.23 Kgs (0.5 lb.)	1.36 Kgs (3 lbs)
Potato Wedges	6/5# bags	96698	30	4 - 4.5 Min.	182°C (360°F)	.45 Kgs (1 lbs.)	1.8 Kgs (4 lbs)
Potato Slices	6/5# bags	96258	30	3 - 3.5 Min.	182°C (360°F)	.45 Kgs (1 lbs.)	1.8 Kgs (4 lbs)
Italian-Style 3-Cheese Mozzarella Sticks	4/3# bags	96279	12	1¼ -1½ Min.	182°C (360°F)	.45 Kgs (1 lbs.)	1.8 Kgs (4 lbs)
Beer Battered Onion Rings	20/8 oz. bags	96287	10	1¼ -1½ Min.	182°C (360°F)	.45 Kgs (1 lbs.)	1.8 Kgs (4 lbs)
Natural Cheddar Nuggets	Bulk Packed	96324	7	1¼ -1½ Min.	182°C (360°F)	.45 Kgs (1 lbs.)	1.8 Kgs (4 lbs)
Jalapeno Peppers	4/3# bags	96325	12	1¾ -2¼ Min.	182°C (360°F)	.45 Kgs (1 lbs.)	1.8 Kgs (4 lbs)

ALWAYS COOK ALL BROASTER RECIPE PRODUCTS UNTIL THE INTERNAL TEMPERATURE REACHES THE FOLLOWING MINIMUMS:
Chicken, White - 170°F; Chicken, Dark - 180°F; Corn Dogs/Pork - 160°F to 170°F; Fish - 155°F

1800 BROASTER RECIPE PRODUCTS COOKING CHART

All cook times are approximate and will vary depending on load size, etc.

Product Description	Package Description	Product Number	Lbs/Case	Cooking Time	Cooking Temperature	Approx. Load - Kgs (Lbs.)	
						MIN	MAX
Jumbo Popcorn Chicken	2/5# bags	96262	10	4 - 4.5 Min.	182°C (360°F)	.45 Kgs (1 lb.)	3.63 Kgs (8 lbs)
Cajun Jumbo Popcorn Chicken	2/5# bags	96277	10	4 - 4.5 Min.	182°C (360°F)	.45 Kgs (1 lb.)	3.63 Kgs (8 lbs)
Chicken Tenders	2/5# bags	96641	10	5 - 6 Min.	182°C (360°F)	.45 Kgs (1 lb.)	3.63 Kgs (8 lbs)
Zesty Home Style Chicken Tenders	2/5# bags	96349	10	5 - 6 Min.	182°C (360°F)	.45 Kgs (1 lb.)	3.63 Kgs (8 lbs)
Chicken Fillets	2/5# bags	96638	10	6 - 7 Min.	182°C (360°F)	.45 Kgs (1 lb.)	3.63 Kgs (8 lbs)
Traditional Wings	2/5# bags	96261	10	8 - 10 Min.	182°C (360°F)	.45 Kgs (1 lb.)	3.63 Kgs (8 lbs)
Hot 'N Spicy Wings	4/5# bags	96639	20	8 - 10 Min.	182°C (360°F)	.45 Kgs (1 lb.)	3.63 Kgs (8 lbs)
Boneless Buffalo Wings	2/5# bags	96318	10	5 - 6 Min.	182°C (360°F)	.45 Kgs (1 lb.)	3.63 Kgs (8 lbs)
Fully-Cooked Oven Roasted Chicken Wings	2/5# bags	96351	10	6 - 7 Min.	182°C (360°F)	.23 Kgs (0.5 lb.)	2.72 Kgs (6 lbs)
Chicken Gizzards	Bulk Packed	96271	10	4 - 6 Min.	182°C (360°F)	.45 Kgs (1 lb.)	3.63 Kgs (8 lbs)
Jumbo Corn Dogs	Bulk Packed	96661	10	Thawed 6 - 7 Min.	182°C (360°F)	.45 Kgs (1 lb.)	3.63 Kgs (8 lbs)
Jumbo Corn Dogs	Bulk Packed	96661	10	Thawed 7 - 8 Min.	168°C (335°F)	.45 Kgs (1 lbs.)	3.63 Kgs (8 lbs)
Jumbo Corn Dogs	Bulk Packed	96661	10	Frozen 13 - 14 Min.	168°C (335°F)	.45 Kgs (1 lbs.)	3.63 Kgs (8 lbs)
Pork Tenderloin	Bulk Packed	96313	9.75	3 - 3.5 Min.	182°C (360°F)	.45 Kgs (1 lbs.)	3.63 Kgs (8 lbs)
Deluxe Pizza Burritos	48 in 7 trays	96316	15	6.5 - 7.5 Min.	182°C (360°F)	.45 Kgs (1 lbs.)	1.13 Kgs (2.5 lb)
Deluxe Beef 'n Bean Burritos	48 in 7 trays	96317	15	5.5 - 6.5 Min.	182°C (360°F)	.45 Kgs (1 lbs.)	1.13 Kgs (2.5 lb)
Deluxe Breakfast Burritos	48 in 7 trays	96323	15	6.5 - 7.5 Min	182°C (360°F)	.45 Kgs (1 lbs.)	1.13 Kgs (2.5 lb)
Catfish Tender Strips	Bulk Packed	96340	10	3.5 - 4 Min	182°C (360°F)	.45 Kgs (1 lbs.)	3.63 Kgs (8 lbs)
Hand-Breaded Style Catfish Fillets	Bulk Packed	96354	10	4 - 5 Min	182°C (360°F)	.45 Kgs (1 lbs.)	3.63 Kgs (8 lbs)
Premium Cod Fillets (2 oz. Natural Cut)	2/5# bags	96329	10	4 - 5 Min.	182°C (360°F)	.23 Kgs (0.5 lb.)	2.72 Kgs (6 lbs)
Premium Cod Fillets (4 oz. Natural Cut)	2/5# bags	96295	10	5 - 6 Min.	182°C (360°F)	.23 Kgs (0.5 lb.)	2.72 Kgs (6 lbs)
Premium Beer-Battered Recipe Shrimp (tail-off)	Bulk Packed	96286	8	2.5 - 3 Min.	182°C (360°F)	.23 Kgs (0.5 lb.)	2.72 Kgs (6 lbs)
Potato Wedges	6/5# bags	96698	30	4 - 4.5 Min.	182°C (360°F)	.45 Kgs (1 lbs.)	3.63 Kgs (8 lbs)
Potato Slices	6/5# bags	96258	30	3 - 3.5 Min.	182°C (360°F)	.45 Kgs (1 lbs.)	3.63 Kgs (8 lbs)
Italian-Style 3-Cheese Mozzarella Sticks	4/3# bags	96279	12	1¼ - 1½ Min.	182°C (360°F)	.45 Kgs (1 lbs.)	3.63 Kgs (8 lbs)
Beer Battered Onion Rings	20/8 oz. bags	96287	10	1¼ - 1½ Min.	182°C (360°F)	.45 Kgs (1 lbs.)	3.63 Kgs (8 lbs)
Natural Cheddar Nuggets	Bulk Packed	96324	7	1¼ - 1½ Min.	182°C (360°F)	.45 Kgs (1 lbs.)	3.63 Kgs (8 lbs)
Jalapeno Peppers	4/3# bags	96325	12	1¾ - 2¼ Min.	182°C (360°F)	.45 Kgs (1 lbs.)	3.63 Kgs (8 lbs)

ALWAYS COOK ALL BROASTER RECIPE PRODUCTS UNTIL THE INTERNAL TEMPERATURE REACHES THE FOLLOWING MINIMUMS:

Chicken, White - 170°F; Chicken, Dark - 180°F; Corn Dogs/Pork - 160°F to 170°F; Fish - 155°F

9 - COOKING OIL CARE AND FILTERING

OIL CARE IMPORTANT

- Store cooking oil at room temperature: 65° - 75° F.
- Do not reuse the oil container.
- Keep oil away from heat and flames.
- Do not store oil near oxidizing agents.

⚠ DANGER Use care when handling hot oil. Oil could splash causing serious burns.

Maximum oil life depends on proper care. See FILTERING and CLEANING. It is very important if the finished product is to be presentable and edible. Useful oil life can be affected by many things:

Oil Quality: Poor quality oil will require replacement more often.

Temperature: Lowering oil temperature setting during slow periods or between business rushes will extend useful oil life.

Volume: The more product cooked, the more often oil will need filtering and replacing.

Type of Coating and Seasoning Used: Ingredients in some coatings can effect the appearance of end product and shorten the useful oil life.

Amount of Care and Filtering Oil Receives: **DO NOT** leave any crumb build up in oil, on cooking well or on food basket. See FILTERING. Oil will need replacing more often if improperly maintained. Straining methods only remove crumbs.

Using a built in filter, Broaster® filter paper and Broaster® filtering compounds, you can increase useful oil life up to 200%.

How can you tell if oil should be replaced? It will show signs of increased smoking or foaming. If not discarded, safety and product quality could be sacrificed.

FILTERING

Filter oil after cooking approximately 35 lbs. (1600) or 65 lbs. (1800) of product, between rush periods and always at the end of each day. Filter oil at 360°F.

WARNING DO NOT use filter pan to transport hot oil. Hot oil could splash causing serious burns.

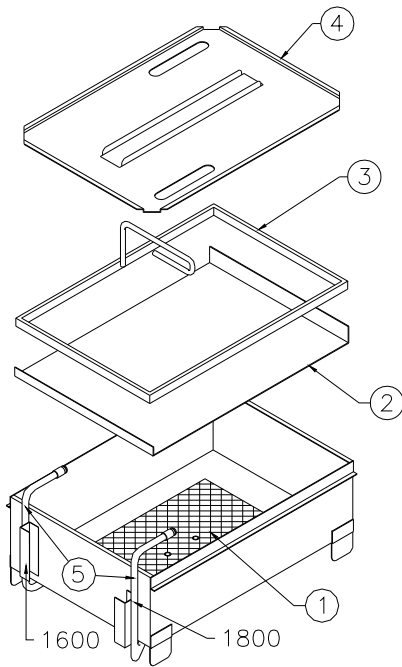

Be sure filter components are assembled correctly. Correct order is (1) Filter Screen on bottom of filter pan, (2) Filter Paper, (3) Filter Hold Down, one cup (1600) or two cups (1800) of Bro-Clean filter media on top of filter paper and/or 5 oz. (1600) or 10 oz. (1800) of XL filtering compound to cooking well, and (4) Filter Cover. For best results change paper after each filter cycle.

1. Be sure filter pan, with components, is installed under unit properly. Make sure O-ring is installed on (5) 1800 Riser Line or inside (5) 1600 Suction Line. Ensure that riser line is fully inserted into suction line. Turn cook/filter switch OFF and OPEN cooking well cover.

2. Using a ram rod, stir oil in a circular motion. This will aid in draining crumbs. Pull cover over cooking well and Open drain valve slowly. If valve becomes obstructed with crumbs, use ram rod to unblock valve.

CAUTION DO NOT allow ramrod point to hit bottom of filter pan. Point of ramrod can penetrate filter paper allowing crumbs and filter compound to pass through filter lines.

3. When oil is drained, pull cover over cooking well completely but **DO NOT CLOSE**. Turn cook/filter switch to FILTER. When oil is flowing out of drain, close drain valve and pump approximately 4 inches (1600) or 8 inches (1800) of oil into cooking well.
4. Being careful of hot oil and cooking well components, use bottom brush to scrub cooking well starting at the top and cleaning downward. On electric units, clean inside and between heating elements. Use element brush to clean between cooking well and heating elements. Be sure no crumbs cover temperature sensor.

1600 Mechanical Temperature Sensor Location:

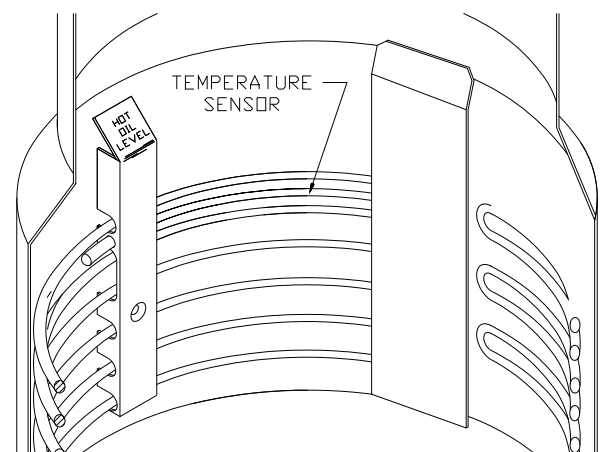

1600/1800E Solid State Temperature Sensor Location:

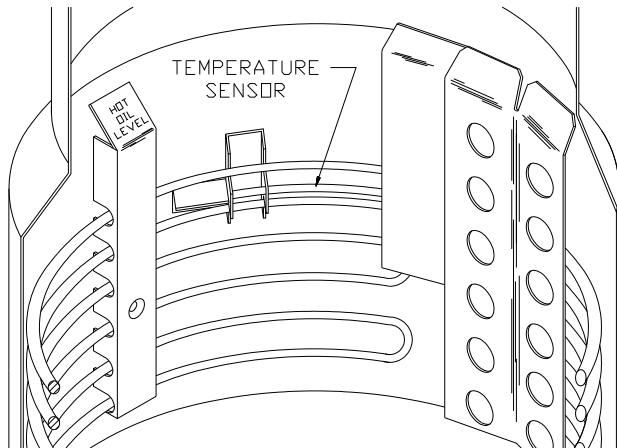

Slowly agitate brush in oil to dislodge any crumbs caught in it. Rinse cooking well using oil remaining in brush when dipped in oil. Drain remaining oil and crumbs. Pull cover over cooking well but **DO NOT CLOSE**. Turn cook/filter switch to **FILTER**. After 5 minutes, push cover assembly toward the rear of the unit. Close drain valve.

5. When air bubbles appear turn cook/filter switch **OFF**.

WARNING Be sure hot oil is at **HOT OIL LEVEL**. Be sure top heating element is covered before turning cook/filter switch to **COOK**.

6. When filter pan has cooled, remove and discard filter paper and filtering compound. Using a clean cloth or paper towel, wipe crumbs from filter hold down, filter pan interior and top & bottom of filter pan cover. Never use soap and water.

WARNING Rags or papers containing cooking oil can catch fire if exposed to heat. Laundering will not remove the oil. Dispose of all oil-soiled papers and rags in a trash container that is in a ventilated area away from all cooking equipment or other heat sources such as direct sunlight.

WARNING **DO NOT** operate unit without filter pan and filter pan cover in its proper position. Filter pan cover must be wiped clean after each filtering cycle.

7. Return clean Filter Pan (equipped with all necessary clean filter components including cover) under the fryer before operation.

FILTERING HINTS

1. Never allow solid shortening to solidify in filter pan or lines.
2. For maximum filtration, recirculate oil. When hot oil is drained into filter pan, turn cook/filter switch to **FILTER**. Let motor run for five minutes with drain valve open. This could extend useful oil life.

NOTICE Ensure cook/filter switch is **OFF** to avoid splashing of oil if motor protector reset button is used.

10 - CLEANING

⚠ DANGER DO NOT heat or boil water in a pressure fryer. Disconnect main power supply. Keep cover and pressure regulating valve OPEN when cooking well contains water. If cover is CLOSED on a well holding hot or boiling water, a large quantity of scalding water could spray out when cover is opened causing serious burns.

⚠ CAUTION Broaster® cooking well cleaner is an irritant. DO NOT take internally. Prolonged skin contact may cause irritation and dryness. Direct eye contact can cause irritation, redness and temporary blurred vision. Ingestion could cause nausea, diarrhea, mucosal and gastric irritation. See first aid instructions on container.

⚠ WARNING When cleaning with water, use Broaster® cooking well cleaner #99500. DO NOT use soaps and detergents. Cooking well cleaner removes unwanted contaminants while also neutralizing harmful acids. These acids, if not removed, may damage cooking well and filter system. To ensure cover remains OPEN when cleaning, install cleaning flag #12814 over latch column. Cleaning flag is supplied with each new unit and in cooking well cleaner. Additional cleaning flags can be ordered.

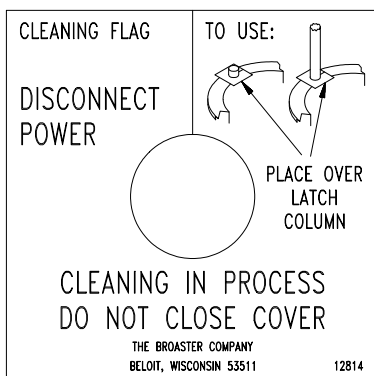

COOKING WELL

1. Turn power switch OFF and disconnect main power supply.
2. Remove filter pan (if your unit has one) from under unit.
3. Drain and discard used oil.
4. OPEN cover and install cleaning flag #12814 over latch column.

NOTICE Quarterly cleaning of Probe Guard (gas & electric) should be done at this point. See PROBE GUARD & BASKET GUIDE CLEANING.

5. Close drain valve. Fill a separate container with 2 gallons of hot water and thoroughly dissolve Broaster® cooking well cleaner (use 93624 - CUP-BROASTER WELL CLEANER for appropriate amount). Add to cooking well then finish filling well to 1" below pressure release port.
6. Soak with cover OPEN for a minimum of 15 minutes. Alternate method: soak overnight up to 12 hours.
7. Drain and discard cleaning mixture. Place pail back under drain valve, connect main power supply and turn on pump for 10 seconds to purge the filter lines.
8. Clean cooking well using a non-metallic heavy duty commercial scouring pad that is USDA approved.
9. Rinse cleaning utensils and cooking well with water. Turn pump on again for 10 seconds to purge the filter lines. Drain and discard rinse water.

10. Close drain valve. Wipe inside of cooking well dry before filling with new oil.

FOOD BASKET

Clean the food basket daily. DO NOT put food basket in a dishwasher. Use warm water and a low suds organic household dish cleanser. Rinse basket with vinegar and water solution (1/2 cup vinegar per gallon of water). Rinse with clear water and completely dry before returning to oil.

UNIT SURFACES

Frequently wipe off excess oil and crumbs with a clean cloth or paper towel. DO NOT use harsh abrasives and chemicals.

WARNING Rags or papers containing cooking oil can catch fire if exposed to heat. Laundering will not remove the oil. Dispose of all oil-soiled papers and rags in a trash container that is in a ventilated area away from all cooking equipment or other heat sources such as direct sunlight.

CONDENSATE PAN

Check liquid level several times daily. Empty as needed.

WARNING Water and hot oil DO NOT mix. DO NOT pour contents into cooking well or filter pan. Hot oil could splash causing serious burns.

SLIDE ROD

Clean daily along with the cover, see COVER. Wipe with a clean cloth or paper towel. No lubrication is necessary.

COVER

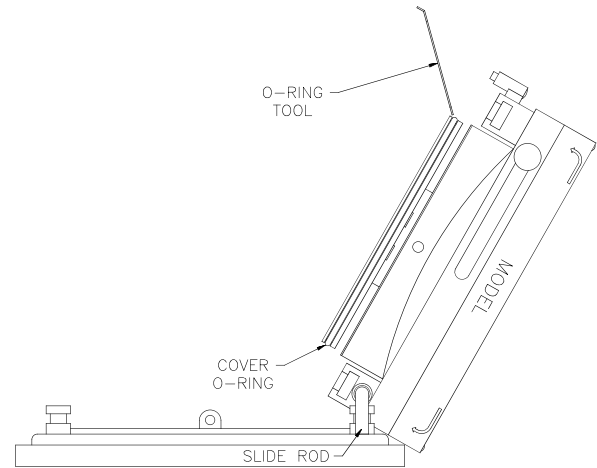

NOTICE

Keep a spare O-ring on hand in case of accidental damage.

1. OPEN cover and slide back 2 to 3 inches.
2. Lift up on left side and pivot assembly to an upright position. DO NOT drop assembly.
3. Rotate cover handle to CLOSED position and push in on center of cover bottom to lock cover and handle. Using O-ring tool #12791 or a small dull tool such as a spoon handle, remove cover O-ring.
4. Clean O-ring using warm water only. DO NOT use detergents. Hold wet rag around O-ring and pull through several times.

5. Clean O-ring groove and cover top and bottom. Use O-ring tool #12791 to clean O-ring groove. Use a non-metallic heavy duty commercial scouring pad that is USDA approved to clean cover.
6. Remove any oil or grease build-up from Pressure Relief Valve and Pressure Gauge Ports on bottom of cover.
7. After cleaning, completely dry. Lubricate O-ring with clean liquid shortening. Install O-ring in O-ring groove.

SPLASH SHIELD

WARNING Allow cover assembly to cool before cleaning. Hot surfaces could cause serious burns.

If your unit is equipped with a two piece splash guard, clean it according to the following instructions:

1. OPEN cover and slide back 2 to 3 inches.
2. Rotate cover handle (1) to a centered position.

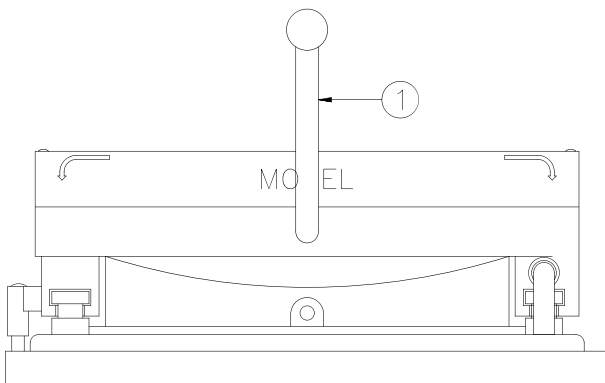

3. Loosen screws (2) attaching back splash shield (3) to splash shield (4).

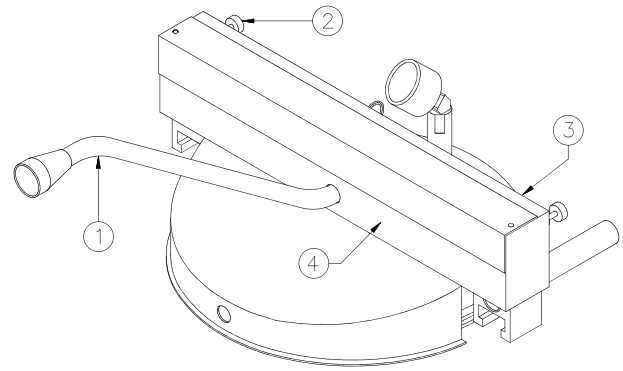

4. Slide splash shield (4) forward and up towards the end of the cover handle (1).
5. Clean the top and underside of splash shield and top of the cover.

NOTICE Make sure back splash shield (3) and splash shield (4) are assembled correctly after cleaning. The cover may not close correctly if they are not.

6. Assemble in reverse order.

Filter Pan & Cover

Wipe all oil off filter pan and both sides of the filter pan cover.

WARNING Rags or papers containing cooking oil can catch fire if exposed to heat. Laundering will not remove the oil. Dispose of all oil-soiled papers and rags in a trash container that is in a ventilated area away from all cooking equipment or other heat sources such as direct sunlight.

Probe Guard & Basket Guides

At least once every 3 months, while cleaning the cooking well, the probe guard and basket guides need to be removed so that any build-up that collects behind them can be cleaned.

1. After emptying the oil and before filling with cleaning solution, remove the probe guard using a flat screwdriver, for Models 1600 and 1800GH, or a 7/16" wrench for the Model 1800E. Remove the probe guard. (See illustrations below)
2. Very carefully remove any debris that is caked on/or around the temperature sensor probe and the hi-limit capillary.
3. On electric fryers, remove the 3 basket guides using a flat screwdriver. Leave the element spacers in place. Carefully clean any build-up that has collected behind the basket guides.

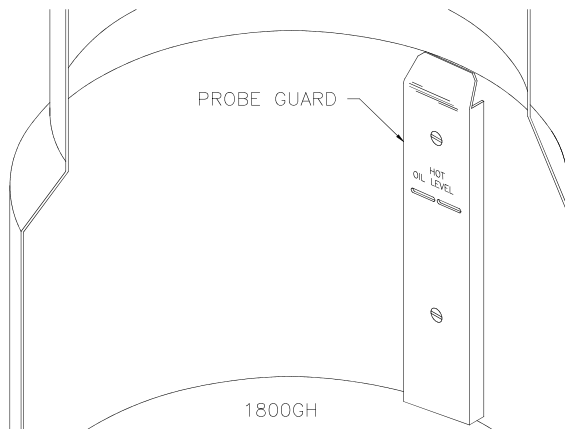
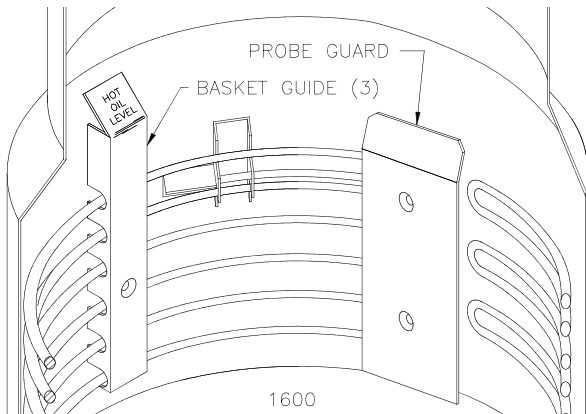

CAUTION Using too much force in this area could result in damage to either the hi-limit capillary or the temperature sensor probe. If either of these components are damaged, the unit will be inoperable until the component is replaced.

4. Leaving the probe guard and basket guides off, fill the cooking well with cleaning solution and clean normally. The probe guard and basket guides can be placed in the cooking well while soaking.
5. After draining the solution, carefully clean area around the probes and behind the basket guides, and inside of the probe guard and basket guides with a non-metallic scouring pad to completely remove any build-up. Rinse and dry the cooking well.
6. Reinstall the probe guard and basket guides with the appropriate hardware using medium (blue) threadlock on screw threads.

CAUTION It is very important to periodically check the screws fastening the probe guard and basket guides to ensure that they do not loosen. If you find that they are coming loose, tighten them immediately.

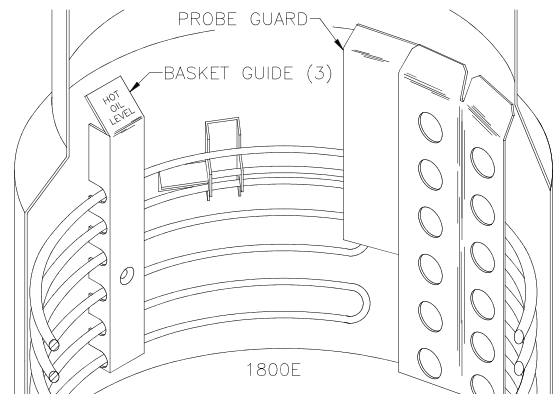

MINIMUM PREVENTIVE MAINTENANCE REQUIREMENTS

	DAILY	WEEKLY	QUARTERLY	YEARLY
Clean Cooking Well		X		
Clean Condensate Pan	X			
Clean Oil Build-up under unit				X
Clean Pressure Relief Valve port & Pressure Gauge Port		X		
Clean Cover and Splash Guard		X		
Clean Food Basket	X			
Clean Temperature Sensor			X	
Clean Filter Pan Cover	After each filtering cycle			
Filter Cooking Oil	See FILTERING			
Clean and Lubricate O-Ring		X		
Slide Rod	X			
Probe Guard & Basket Guides			X	

NOTICE

If cooking volume is high, perform above requirements more frequently.

11 - SHUTDOWN

⚠ WARNING Rags or papers containing cooking oil can catch fire if exposed to heat. Laundering will not remove the oil. Dispose of all oil-soiled papers and rags in a trash container that is in a ventilated area away from all cooking equipment or other heat sources such as direct sunlight.

NIGHTLY

⚠ WARNING *1600 Mechanical Controls:* If at any time the unit fails to operate properly when the cook/filter switch is moved to the cook position, contact your local Broaster Company representative for service immediately. *1600/1800E Solid State Controls:* If at any time the POWER ON light does not turn off when the cook/filter switch is moved to the OFF position, contact your local Broaster Company representative for service immediately.

1. Turn cook/filter switch OFF.
2. Filter cooking oil. See COOKING OIL CARE AND FILTERING.
3. **1800GH:** Turn gas valve and manual gas shut off valve to OFF.
4. Wipe oil and crumbs from unit surfaces with a clean cloth.
5. Clean food basket.
6. Clean condensate pan.

SEASONAL

1. See COOKING OIL CARE AND FILTERING. Discard cooking oil.
2. See CLEANING.
3. Turn main circuit breaker OFF and unplug electrical cord.
4. **1800GH:** Turn gas valve, manual gas shut off valve and main gas supply OFF.
5. Clean condensate pan.
6. Wipe oil and crumbs from unit surfaces with a clean cloth.
7. Lubricate cover O-ring and food basket with olive oil.
8. CLOSE cover and pressure regulating valve.

12 - TROUBLESHOOTING

All adjustments and repairs shall be made by an authorized Broaster Company representative.

ELECTRICAL TIPS

COMPLAINT	CAUSE	REMEDY
POWER ON light not illuminated	<ol style="list-style-type: none"> 1. Main power OFF 2. Cook/filter switch OFF 3. Hi-limit tripped (1800E and 1600 solid state) 4. Unplugged 	<ol style="list-style-type: none"> 1. Turn ON 2. Turn to COOK 3. Turn cook/filter switch OFF. Contact service person. 4. Plug in
Timer will not time	<ol style="list-style-type: none"> 1. Main power OFF 2. Cook/filter switch OFF 3. Solid state controller in program mode 4. Pressure regulating valve OPEN 	<ol style="list-style-type: none"> 1. Turn ON 2. Turn to COOK 3. Exit program mode 4. CLOSE
HEAT ON light not illuminated	<ol style="list-style-type: none"> 1. Main power OFF 2. Cook/filter switch OFF 3. Solid state controller in program mode 4. Oil temperature has reached programmed temperature 5. Temperature control OFF (1600) 	<ol style="list-style-type: none"> 1. Turn ON 2. Turn to COOK 3. Exit program mode 4. Unit ready to cook in 5. Turn temperature control ON. Temperature control may not be cycling on and off (1600).

SOLID STATE CONTROLLER TIPS

COMPLAINT	CAUSE	REMEDY
Display reads FAIL	1. There is a controller failure	1. Turn cook/filter switch OFF. Contact service person.
Display reads HI	1. Oil temperature too high	1. Turn cook/filter switch OFF. Contact service person.
Display reads PROB	1. There is a temperature sensor probe failure	1. Turn cook/filter switch OFF. Contact service person.
Display reads CHEC	<ol style="list-style-type: none"> 1. Gas valve not ON (1800GH) 2. Pilot light will not light (1800GH) 3. Open or faulty wall fuse 4. Oil temperature not rising properly 	<ol style="list-style-type: none"> 1. Turn ON 2. Turn ON manual gas shut off valve 3. Check wall fuse or circuit breaker 4. Turn cook/filter switch OFF. Contact service person.



SMART TOUCH CONTROLLER TIPS

COMPLAINT	CAUSE	1800E REMEDY	1800GH REMEDY
Display reads HEATER FAULT	Oil temperature not rising properly	* Call for service	* Remove anything causing a draft by the unit (like a fan). * Turn on the gas valve. * Call for service
Display is blank	Screen not calibrated	* With unit off, place finger on screen and hold while turning unit on. Touch the small box in the upper left corner until it moves to the upper right corner, then touch it again until it moves to the lower left corner, then touch it again until it disappears. Controller will reboot. * Call for service	
Display doesn't respond when touched			
Display reads PROBE FAULT	* Probe circuit is open or shorted *Probe wires are connected in reverse *Temperature changes more than 100F in two seconds	* Call for service	* Call for service
Display reads HI TEMP FAULT	Temp reaches 415F	* Call for service	* Call for service
Display reads INTERNAL FAULT	Internal fault detected	* Call for service	* Call for service
Display reads C1 FAULT	C1 contactor is stuck in the closed position	* Call for service	* Call for service

1800GH GAS TIPS

COMPLAINT	CAUSE	REMEDY
Pilot burner won't ignite	<ol style="list-style-type: none">1. Gas valve OFF2. Air in pilot gas line3. Gas shut-off valve OFF	<ol style="list-style-type: none">1. Slide switch to ON2. See MODEL 1800GH LIGHTING INSTRUCTIONS3. Turn ON
Main burner won't ignite	<ol style="list-style-type: none">1. Pilot burner not lit2. Gas control OFF3. Controller in program mode4. Cook/filter switch OFF5. Hi-limit tripped	<ol style="list-style-type: none">1. See MODEL 1800GH LIGHTING INSTRUCTIONS2. Turn ON3. Exit program mode4. Turn to COOK5. Turn cook/filter switch OFF. Contact service person.

COVER AND YOKE TIPS

COMPLAINT	CAUSE	REMEDY
Cover hard to CLOSE	<ol style="list-style-type: none"> 1. O-ring dry or dirty 2. O-ring groove dirty 3. Hard O-ring 	<ol style="list-style-type: none"> 1. Clean and lubricate 2. Clean 3. Replace
Cover won't OPEN  WARNING Never use force to OPEN cover.	<ol style="list-style-type: none"> 1. O-ring dry or dirty 2. O-ring groove dirty 3. Hard O-ring 4. Pressure not released 5. Pressure regulating valve out of adjustment 	<ol style="list-style-type: none"> 1. Clean and lubricate 2. Clean 3. Replace 4. OPEN pressure regulating valve 3. Contact service person
O-ring Break  CAUTION DO NOT rest basket on top flange of cooking well. Damage to area in contact with o-ring can cause leaking under pressure or O-ring failure.	<ol style="list-style-type: none"> 1. O-ring groove dirty 2. Nicks in cooking well or cover 	<ol style="list-style-type: none"> 1. Clean 2. Remove
Pressure Gauge does not indicate rising pressure when exhaust valve is closed.	<ol style="list-style-type: none"> 1. Port is plugged 2. Pressure gauge is damaged 	<ol style="list-style-type: none"> 1. Clean port on bottom of cover 2. Replace pressure gauge

PRESSURE SYSTEM TIPS



DO NOT attempt to tighten, repair or replace any fitting, line or component when there is pressure in the cooking well. Hot oil could spray out under pressure causing serious burns.

COMPLAINT	CAUSE	REMEDY
No pressure	<ol style="list-style-type: none">1. Pressure regulating valve OPEN2. Pressure regulating valve dirty or blocked open3. Leaks around cover O-ring	<ol style="list-style-type: none">1. CLOSE2. Contact service person3. Replace O-ring
Excess pressure		<ol style="list-style-type: none">1. Turn cook/filter switch OFF. Contact service person.

PRODUCT TIPS

Fresh Chicken:

COMPLAINT	CAUSE	REMEDY
Product too light	<ol style="list-style-type: none">1. Low oil temperature2. No coating3. Not done4. Food basket overloaded	<ol style="list-style-type: none">1. Check cook temperature2. Check procedures3. Increase cook time4. Decrease load
Product too dark	<ol style="list-style-type: none">1. High oil temperature2. Wrong coating3. Breaded too long4. Old oil	<ol style="list-style-type: none">1. Check cook temperature2. Check procedures3. Discard4. Change oil
Product not done	<ol style="list-style-type: none">1. Low oil temperature2. Food basket overloaded3. Cook time too short	<ol style="list-style-type: none">1. Check cook temperature2. Decrease load3. Increase cook time
No flavor	<ol style="list-style-type: none">1. Improper marination	<ol style="list-style-type: none">1. Check procedures
White spots	<ol style="list-style-type: none">1. Product stuck together2. Food basket overloaded	<ol style="list-style-type: none">1. Float basket while loading2. Decrease load size
Dark spots	<ol style="list-style-type: none">1. Dirty oil	<ol style="list-style-type: none">1. Filter or replace

Frozen IQF Chicken

COMPLAINT	CAUSE	REMEDY
Product too light	<ol style="list-style-type: none"> 1. Low oil temperature 2. Not done 3. Food basket overloaded 	<ol style="list-style-type: none"> 1. Check cook temperature 2. Increase cook time 3. Decrease load
Product too dark	<ol style="list-style-type: none"> 1. High oil temperature 2. Overcooked 3. Oil old 4. Thawed and refrozen 	<ol style="list-style-type: none"> 1. Check cook temperature 2. Decrease cook time 3. Change oil 4. Keep product at 0°F or below
Product not done	<ol style="list-style-type: none"> 1. Low oil temperature 2. Food basket overloaded 3. Cook time too short 	<ol style="list-style-type: none"> 1. Check cook temperature 2. Decrease load 3. Increase cook time
No flavor	<ol style="list-style-type: none"> 1. Overcooked 2. Old product 	<ol style="list-style-type: none"> 1. Check cook time 2. Discard
White spots	<ol style="list-style-type: none"> 1. Product stuck together 2. Food basket overloaded 	<ol style="list-style-type: none"> 1. Float basket while loading 2. Decrease load size
Dark spots	<ol style="list-style-type: none"> 1. Dirty oil 	<ol style="list-style-type: none"> 1. Filter or replace

FILTERING TIPS

COMPLAINT	CAUSE	REMEDY
<p>Motor will not start</p> <p>⚠ WARNING Turn cook/filter switch to OFF position to avoid splashing of oil when motor protector reset button is pushed.</p>	<ol style="list-style-type: none"> 1. Overload tripped 2. Cook/filter switch OFF 3. Open or faulty wall fuse or circuit breaker 	<ol style="list-style-type: none"> 1. Wait for overload to cool. Push red motor protector reset button located on rear of motor. 2. Turn to FILTER 3. Check wall fuse or circuit breaker
<p>Motor hums but will not start</p>	<ol style="list-style-type: none"> 1. Solidified shortening in pump 2. Crumbs in pump 	<ol style="list-style-type: none"> 1. Turn cook/filter switch OFF. Contact service person. 2. Turn cook/filter switch OFF. Contact service person.
<p>Motor starts but will not pump</p>	<ol style="list-style-type: none"> 1. Filter pan not completely installed 2. O-ring on riser line not installed 3. Solidified shortening in piping or filter pan 	<ol style="list-style-type: none"> 1. Firmly push filter pan in 2. See FILTERING 3. Turn cook/filter switch OFF. Contact service person.
<p>Motor starts but will not pump or stops at any level</p>	<ol style="list-style-type: none"> 1. Filter paper or hold down improperly installed 2. Not using enough Broaster[®] filtering compound 	<ol style="list-style-type: none"> 1. See COOKING OIL CARE AND FILTERING 2. Next filtering cycle, make sure proper amount of Broaster[®] filtering compound is used
<p>Motor starts but stops pumping when oil is level with top of hold down, approximately 1 inch of oil in bottom</p>	<ol style="list-style-type: none"> 1. Filter paper improperly installed or crumbs under filter paper or hold down 	<ol style="list-style-type: none"> 1. See COOKING OIL CARE AND FILTERING



Broaster Company
2855 Cranston Road, Beloit, WI 53511-3991
608/365-0193
broaster.com