

BROASTER®

EQUIPMENT

OPERATION MANUAL

BROASTER® 2400 PRESSURE FRYER

Be sure ALL installers read, understand, and have access to this manual at all times.



Genuine Broaster Chicken®, Broasted®, Broaster Chicken®, Broaster Foods®, and Broasterie® are registered trademarks. Usage is available only to licensed operators with written authorization from the Broaster Company.

Broaster Company
2855 Cranston Road, Beloit, WI 53511-3991
608/365-0193 broaster.com

FOR YOUR SAFETY

Do not use or store gasoline or other flammable vapors or liquids in the vicinity of this or any other appliance.

⚠ WARNING Improper installation, adjustments, alteration, service or maintenance can cause property damage, injury or death. Read the installation, operating and maintenance instructions thoroughly before installing or servicing this equipment.

For the sake of safety and clarity, the following words used in this manual are defined as follows:

⚠ DANGER Indicates an imminently hazardous situation which, if not avoided, could result in serious injury or death.

⚠ WARNING Indicates a potentially hazardous situation which, if not avoided, could result in serious injury or death.

⚠ CAUTION Indicates a potentially hazardous situation which, if not avoided, could result in minor injury, property damage or both.

All adjustments and repairs shall be made by an authorized Broaster Company representative.

If there is a power failure, turn cook/filter switch OFF. On the Model 2400GH, also slide switch on gas valve OFF. DO NOT attempt to operate unit during a power failure.

⚠ WARNING Failure to read and understand this manual completely could result in serious injury or death. Be sure ALL operators read, understand and have access to this manual at all times.

⚠ WARNING Rags or paper containing cooking oil can catch fire if exposed to heat. Laundering will not remove the oil. Dispose of all oil-soiled papers and rags in a trash container that is in a ventilated area away from all cooking equipment or other heat sources such as direct sunlight.

⚠ WARNING If at any time the **POWER ON** light does not turn off when the cook/filter switch is moved to the OFF position, disconnect the power to the fryer and contact your local Broaster Company representative for service immediately.

⚠ WARNING DO NOT operate unit without filter pan and filter pan cover in its proper position. Filter pan cover must be wiped clean after each filtering cycle. Make sure Pressure Relief Valve and Pressure Gauge ports on bottom of cover are clear of any oil or grease buildup.

⚠ WARNING Make sure Pressure Relief Valve and Pressure Gauge ports on bottom of cover are clear of any oil or grease buildup.

2400GH: Post, in prominent locations, instructions to be followed in the event that the user smells gas. This information can be obtained from your local gas supplier.

cont'd on next page

⚠ WARNING Make sure a restraining device is used that complies with the Standard for *Commercial Gas Ranges*, ANSI Z83.11/ CSA 1.8 to guard against transmission of strain to the gas connectors.

⚠ DANGER Failure to restrain the fryer could allow it to move, causing hot shortening to spill out, or a possible break in the gas line causing an explosive condition.

TABLE OF CONTENTS

1 – LIMITED WARRANTY	1-1
2 – OWNER’S RESPONSIBILITY	2-1
3 – INSTALLATION INSPECTION	3-1
Gas Conversion	3-1
4 – GETTING TO KNOW YOUR BROASTER® PRESSURE FRYER	4-1
5 – PRE-COOKING PREPARATIONS	5-1
O-RING LUBRICATION	5-1
COVER CHECK	5-1
COOKING OIL	5-1
Liquid Oil	5-1
Solid Shortening	5-1
OIL LEVEL	5-2
FOOD AND CONDIMENTS	5-2
2400GH LIGHTING INSTRUCTIONS	5-3
Start Up	5-3
Shut Down	5-3
6 – CONTROL PANEL	6-1
TEMP-N-TIME FAMILIARIZATION	6-1
CONTROLLER BASIC PROGRAMMING	6-2
Normal Operating Mode	6-2
Set Temperature	6-2
Set Time	6-2
Set AUTO COMP (Automatic Time Compensation)	6-2
Reset Cycle Counter	6-2
Preset Cook Mode Programming METHOD 1	6-3
Preset Cook Mode Programming METHOD 2	6-3
Choose Preset Cook Cycle:	6-3
Change Cook Time:	6-3
Change Cook Temperature	6-3
Activate/Deactivate Auto Comp	6-4
Advance to Next Preset	6-4
SMART TOUCH CONTROL PANEL.....	6-6
COOK TAB.....	6-6
Cook Time Display	6-6
Temperature Display	6-6
Select Preset Display	6-7
Cycles Since last Filtered	6-7
FILTER TAB	6-8
SETUP TAB	6-9
PIN Number	6-9

Time & Date Adjustment	6-9
Temperature Adjustment.....	6-9
Energy Save Setting	6-10
Pin Maintenance	6-10
Presets	6-11
Name Edit	6-11
Position Edit	6-11
Time & Temperature Edit	6-11
Auto Comp On / Off	6-10
Active	6-11
Add New	6-12
Menu Transfer	6-12
Export Menu	6-12
Load Menu	6-13
Shortening Management	6-13
Language Selection	6-13
Alert Settings	6-13
HELP TAB	6-14

7 – COOKING WEIGHT, TEMPERATURE AND TIME	7-1
FRESH PRODUCTS	7-1
INDIVIDUALLY QUICK FROZEN (IQF) CHICKEN, FROZEN	7-2
BROASTER FOODS COOKING CHART FOR 2400 PRESSURE FRYER	7-3

8 – COOKING OIL CARE AND FILTERING	8-1
OIL CARE	8-1
FILTERING	8-2
FILTERING HINTS	8-3

9 – CLEANING	9-1
COOKING WELL	9-1
FOOD BASKET	9-2
UNIT SURFACES	9-2
CONDENSATE PAN	9-2
SLIDE RODS	9-2
COVER	9-2
SPLASH SHIELD	9-3
GAS SPRING COVERS	9-3
PROBE GUARD & BASKET GUIDES	9-4
MINIMUM PREVENTIVE MAINTENANCE REQUIREMENTS	9-5

10 – SHUTDOWN	10-1
NIGHTLY	10-1
SEASONAL	10-2

11 – TROUBLESHOOTING	11-1
ELECTRICAL TIPS	11-1
SOLID STATE CONTROLLER TIPS	11-2
SMART TOUCH CONTROLLER TIPS	11-3
GAS TIPS	11-4
COVER, YOKE, AND LIFT TIPS	11-5
PRESSURE SYSTEM TIPS	11-6
PRODUCT TIPS	11-7
Fresh Chicken	11-7
Individually Quick Frozen (IQF) Chicken	11-8
FILTERING TIPS	11-9

1 - LIMITED WARRANTY Parts and Labor

Subject to the terms and conditions of this warranty, The Broaster Company (Company) warrants that all equipment and parts manufactured or sold by the Company and purchased new from an authorized Company distributor are free from defects in material and workmanship. The warranty begins on the date of installation, or one year from the date of manufacture, whichever occurs earlier. The term of the warranty is **one year for all non-wearable parts, two years on Solid State controllers, and ten years on the Welded Stainless Steel Cooking Well**. To qualify for warranty coverage, all units must be installed by a qualified installer under supervision by an authorized distributor in accordance with applicable laws and regulations. Warranty coverage is extended to the original purchaser only and is void if the equipment is resold or relocated. If an authorized Company distributor is notified of a warranty claim during the warranty period, the Company will at its option replace, recondition, or repair at its factory any part or parts of the equipment which the Company judges defective, provided the equipment has been subjected to normal usage, properly installed, operated and serviced in accordance with Company operating instructions, and there is no evidence of accident, alteration or abuse of the equipment or the use of unauthorized repair methods. All parts replaced under this warranty carry only the unexpired term of the warranty.

Extended cooking well warranty will cover the cooking well only and does not include any parts attached to the cooking well, including: probe guards, basket guides, latch columns, latch column blocks, insulation, splash shield interlock, drain valve, filter lines and fittings, high limit, thermostat, temperature sensor probe, combustion chamber and flue, elements, burner, all mounting hardware. The aforementioned excluded parts are covered under the 1-year parts warranty. The extended warranty does not cover any cooking well that fails due to any misuse or abuse.

Any warranty claim on the cooking well must be presented to The Broaster Company or authorized Broaster Distributor from whom the pressure fryer was purchased. Repairs will be made by The Broaster Company only. Any freight charges and distributor labor costs to install the repaired cooking well, as well as the cost of any other parts replaced will be the responsibility of the equipment owner.

Service under this warranty shall be furnished only by an authorized Company distributor. The Company does not send service representatives to furnish warranty service. Your authorized Company distributor should be contacted for warranty service.

This warranty covers **on-site labor charges only**, at a fixed rate, for one year, on new equipment only. The warranty period begins on the date of installation or one year from the date of manufacture, whichever occurs earlier. Transportation charges, trip charges, zone fees, or other expenses in connection with warranty service are the obligation of the owner.

This warranty shall be void unless genuine Broaster® parts & filter paper, Bro-Clean™ filtering compound, and Broaster Cooking Well Cleaner is used in conjunction with the equipment.

This warranty does not apply to consumable items and supplies such as O-rings, food baskets, bulbs, gaskets and lamps.

The foregoing warranty is made in lieu of all other warranties, express or implied, and the Company specifically disclaims any implied warranties of merchantability or fitness for a particular purpose. The Company's full obligation under this warranty, and the purchaser's sole remedy, shall be limited to replacement, reconditioning or repair as specified above.

IN NO EVENT SHALL THE COMPANY BE LIABLE TO THE ORIGINAL OWNER OR ANY OTHER PERSON FOR ANY INCIDENTAL, CONSEQUENTIAL OR SPECIAL DAMAGES RESULTING FROM THE USE OR INABILITY TO USE THE EQUIPMENT COVERED HEREBY, WHETHER ARISING FROM BREACH OF WARRANTY, STRICT LIABILITY OR OTHERWISE.

The Company reserves the right to change or improve its products in any way without obligation to alter products previously manufactured.

Used Company equipment or Company equipment not purchased from an authorized distributor carries no warranty expressed or implied.

2 – OWNER'S RESPONSIBILITY

It is the owner's responsibility to:

- Ensure the Broaster[®] Pressure Fryer is properly maintained.
- Ensure all safety devices and warning signs are in their original location and are legible.
- Allow only properly trained personnel to operate, clean and maintain a Broaster[®] Pressure Fryer.
- Retain this manual for future reference.
- Ensure main power supply is disconnected before the unit is serviced.
- When you sell, trade, dispose of or give away your Broaster[®] Pressure Fryer, you must make sure that all safety devices and warning signs are intact and legible and the operation manual is included with the unit.
- **2400GH:** Keep burner area free and clear of all combustible materials.
- **2400GH:** DO NOT obstruct exhaust flue or open area around bottom of unit at the front, back and sides which would restrict the flow of combustion and ventilation air.

If you need replacement warning signs or manuals, contact an authorized Broaster Company representative or the Broaster Company at 608/365-0193.

The Customer Service Department at the Broaster Company should be contacted at the time of sale or disposal of the Broaster[®] Pressure Fryer so records may be updated.

If you are a new owner of a used unit or have relocated your Broaster Pressure Fryer, please take a minute to notify us by completing the Pre-Owned Equipment Registration page on our website. It is NOT a warranty registration.

broaster.com/preowned-registration.htm

This information enables the Broaster Company to better serve you and keep you informed of changes in equipment, condiments, or service bulletins.

3 – INSTALLATION INSPECTION

Before operating unit, be sure installation meets all requirements in the Installation Manual provided with your unit.

CAUTION Follow cleaning instructions as outlined in this manual before operating for the first time. See “Cleaning” on page 9-1.

- A remote circuit breaker or fuse should be installed in the main power supply located in a path of exit and clearly identified.
- To avoid splashing of hot liquid, unit must be restrained to prevent tipping. This can be done by installing the unit in a battery of appliances, in an alcove or with adequate ties.
- See **Safety Relief Valve** on page 4-3. DO NOT install unit where traffic areas are on either side or behind unit.

2400GH:

WARNING Electrical Grounding Instructions—The Model 2400GH is equipped with a three-prong (grounding) plug to protect against shock hazard. The plug must be plugged directly into a properly grounded three-prong receptacle. **DO NOT** cut or remove the grounding prong from this plug.

- A gas shutoff valve, installed in gas supply line, should be located in a path of exit and clearly identified.

Gas Conversion USA and Canada

- Contact your local Broaster Company representative for converting from one type of gas to another.

European Union

- Units manufactured for use in the European Union are not convertible from one type of gas to another.

4 – GETTING TO KNOW YOUR BROASTER® PRESSURE FRYER

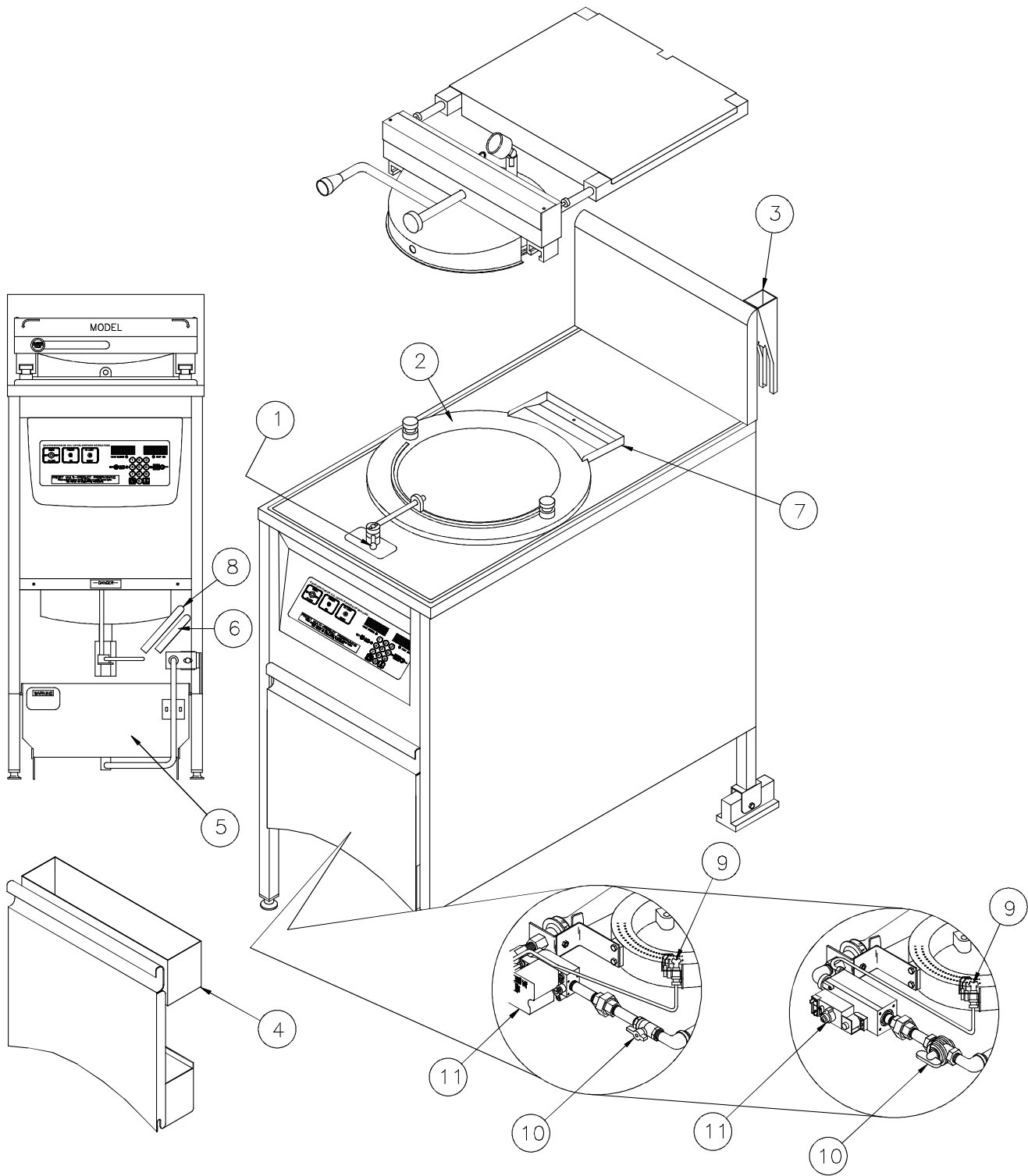

FOR 2400GH

FOR 2400GHCE

FOR GAS MODELS ONLY

1. **Pressure Regulating Valve:** Opens and closes pressure regulating valve. When cover and valve are CLOSED, this valve seals the cooking well, allowing pressure to build. Valve is preset to maintain pressure at 12-14 PSI during a cooking cycle. When OPEN, all pressure is exhausted and timer stops timing.
2. **Cooking Well:** Holds cooking oil.
3. **Basket Lifter Holder:** Holds basket lifter when not in use.
4. **Condensate Pan:** Holds condensation drained from exhaust tank. Check liquid level several times daily. Empty as needed.

⚠ WARNING Water and hot oil **DO NOT** mix. **DO NOT** pour contents of condensate pan into cooking well or filter pan. Hot oil could splash, causing serious burns.

5. **Filter Pan:** Holds filter components and filtering compound used to filter hot oil.

⚠ CAUTION HOT Surfaces!

⚠ WARNING Hot shortening! **DO NOT** use this container to transport hot shortening. Hot shortening could splash, causing serious burns.

6. **Exhaust Drain Tube:** Directs condensation from the exhaust tank into condensate pan.
7. **Countertop Drip Pan:** Collects condensate from the open cooking well and directs it to the Drip Pan Drain Line. Drip Pan is removable for cleaning.
8. **Drip Pan Drain Line:** Directs countertop liquid toward Condensate Pan.

9. **Pilot Burner:** A small flame used to ignite the main burner.
10. **Manual Gas Shut Off Valve:** Shuts off gas flow to the gas valve. Gas will flow when handle is in line with pipe. Turning handle crosswise to the pipe stops gas flow.
11. **Gas Valve:** Regulates gas supply. The valve has a two-position switch: OFF stops all gas flow and ON allows gas flow to pilot and main burner as needed.

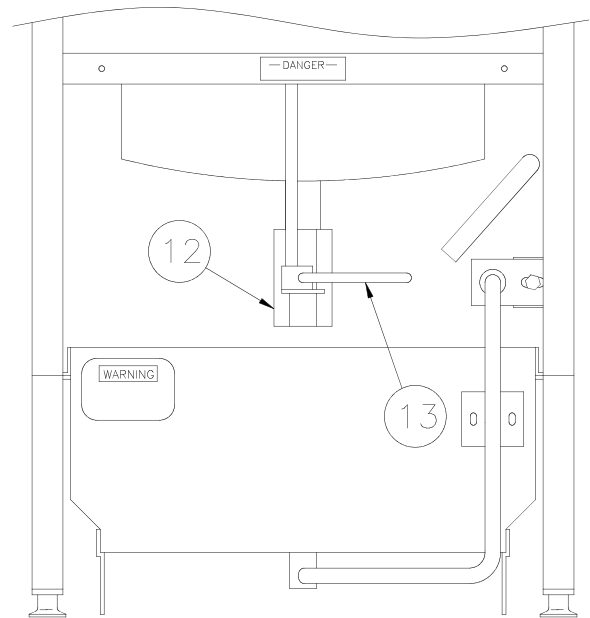

12. **Drain Valve:** Used to drain cooking oil from cooking well into filter pan or container made for handling hot oil.

⚠ DANGER Never drain oil unless cook/filter switch is OFF and pressure regulating valve is OPEN. Hot oil could spray out under pressure, causing serious burns.

13. **Drain Valve Handle:** Opens and closes drain valve. When handle is horizontal, valve is closed. When vertical, valve is open.

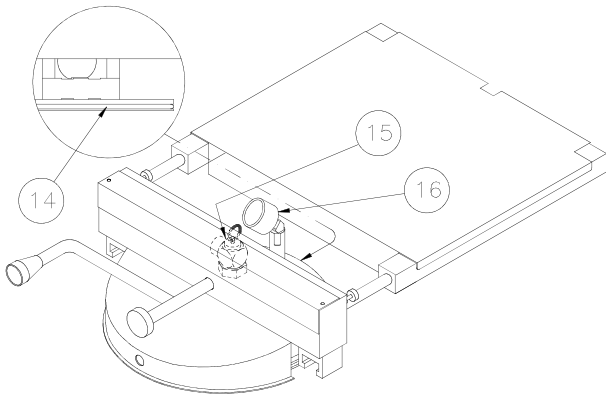

14. Cover O-Ring: Forms a seal when cover is lowered into the cooking well.

15. Safety Relief Valve: This valve will open in the event pressure in the cooking well meets relief pressure of valve. A properly installed valve has the outlet facing toward rear corner of the countertop. DO NOT use valve to release pressure at the end of a cooking cycle. If valve leaks during normal operation, DO NOT operate the unit until valve is replaced by an authorized Broaster Company representative.

⚠ WARNING Keep away from safety relief valve opening unless wearing heat and steam protective apparel. Escaping steam could cause serious burns.

Test valve once a month. Also test before and after an extended shut-down. Using a hot mitt, lift valve handle during a cook cycle until pressure is released from cooking well. Allow valve to snap closed.

16. Pressure Gauge: Indicates pressure within the cooking well. Normal operating pressure is 12-14 PSI.

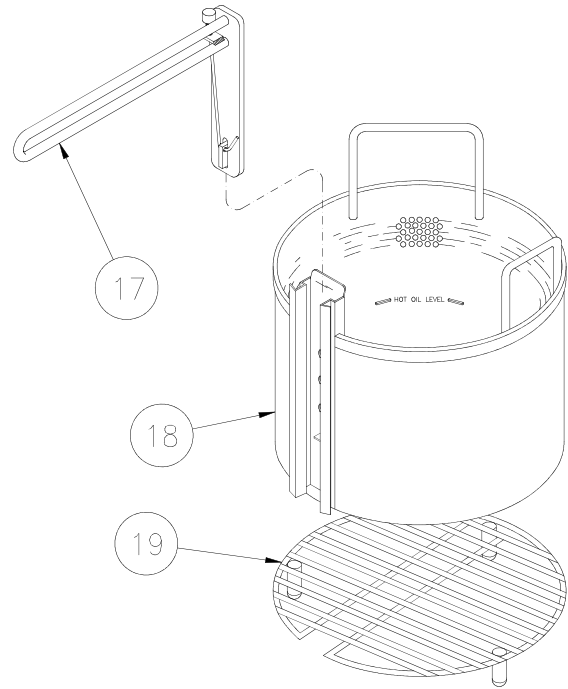

17. Basket Lifter: Used to raise and lower food basket into the cooking well.

18. Food Basket: Holds product for cooking. Indicates proper level of oil at operating temperature.

19. Basket Support Grate: Used in the bottom of the cooking well to support the basket w/o feet at the proper height. (Model 2400GH only)

⚠ WARNING Basket, lifting handle and basket support grate are hot, use gloves when handling. Hot surfaces could cause serious burns.

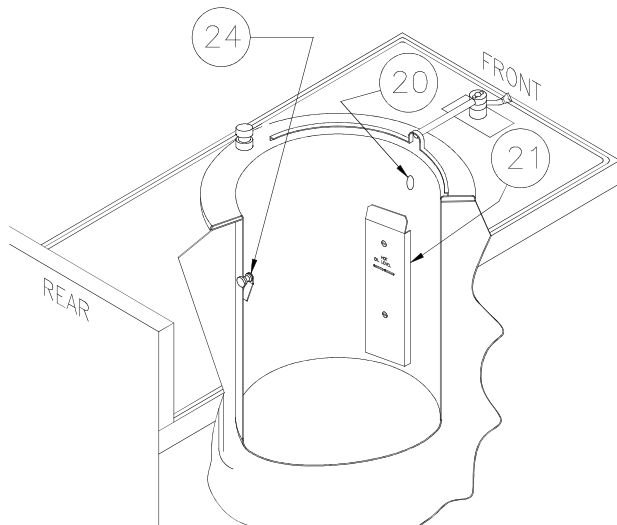

20. Pressure Port: When cover is CLOSED while cooking, all steam passes through this port into the pressure regulating valve.

21. Capillary Guard: Protects temperature sensor probe, hi-limit bulb and capillary from damage. Includes hot and cold oil level indicator.

CAUTION Check oil level before turning cook/filter switch to COOK.

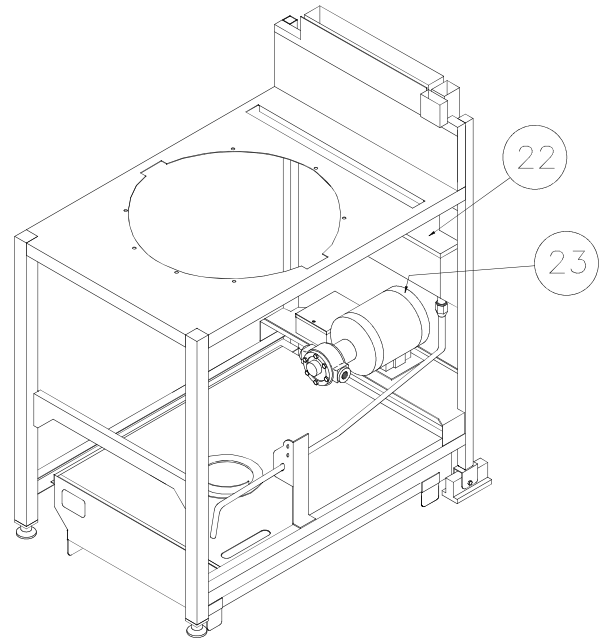

22. Exhaust Tank: Steam and vapors are exhausted through this tank.

23. Filter Pump and Motor: When filtering, returns oil to cooking well.

24. Basket Rest: Holds and tilts basket for draining when removing cooked product from oil or loading uncooked product.

CAUTION DO NOT rest basket on top flange of cooking well. Damage to area in contact with O-ring can cause leaking under pressure or O-ring failure.

5 – PRE-COOKING PREPARATIONS

O-RING LUBRICATION

Lubricate filter pan riser line O-ring and cover O-ring with cooking oil (see COVER steps 1 through 3, page 9-2).

COVER CHECK

To OPEN cover, push down on cover handle then rotate handle clockwise. Slide assembly to the rear of the unit. To CLOSE, pull assembly toward the front and rotate handle counterclockwise.

- Always fully rotate handle OPEN or CLOSED.
- Never use force to OPEN cover. OPEN only when no pressure is present in the cooking well.
- If cover will not OPEN easily, be sure pressure regulating valve is OPEN. If cover will still not OPEN, turn cook/filter switch OFF. DO NOT operate unit until it has been serviced by an authorized Broaster Company representative.
- When cover has been placed in its raised position, it should remain raised until it is deliberately lowered. If the cover will not remain raised, turn cook/filter switch OFF. DO NOT operate unit until it has been serviced by an authorized Broaster Company representative.

COOKING OIL

The words “oil” and “shortening” are used to describe a high quality cooking medium manufactured for deep frying.



Check oil level before turning cook/filter switch to COOK.



Danger of fire exists if the oil level is below the minimum level.



Using old oil reduces flash-point, increasing the risk of surge boiling.



Use care when handling hot oil. Oil could splash, causing serious burns.

Fill cooking well using one of the following methods:

Liquid Oil

Use Broaster® liquid oils or a high quality liquid oil manufactured for deep frying.

Solid Shortening

(Any cooking medium that is solid at room temperature)



DO NOT heat solid shortening on a stove or other appliance prior to placing in cooking well. Hot shortening could splash, causing serious burns.

DO NOT leave unit unattended when melting solid shortening. HOT OIL LEVEL must be maintained. Solid shortening must be soft enough to be packed around and completely cover heating elements on the 2400E and sides and bottom of cooking well on the 2400GH. If not, there will be places on heating elements and cooking well not covered with shortening. During the heating period, these bare spots will be hot spots. They could discolor the cooking well, damage a heating element, scorch or burn shortening, reducing its useful life.

OIL LEVEL

Close drain valve. Fill cooking well with oil to COLD OIL LEVEL. Oil will expand when heated.

⚠ WARNING Be sure hot oil is at **HOT OIL LEVEL**. Be sure top heating element is covered before turning cook/filter switch to **COOK**.

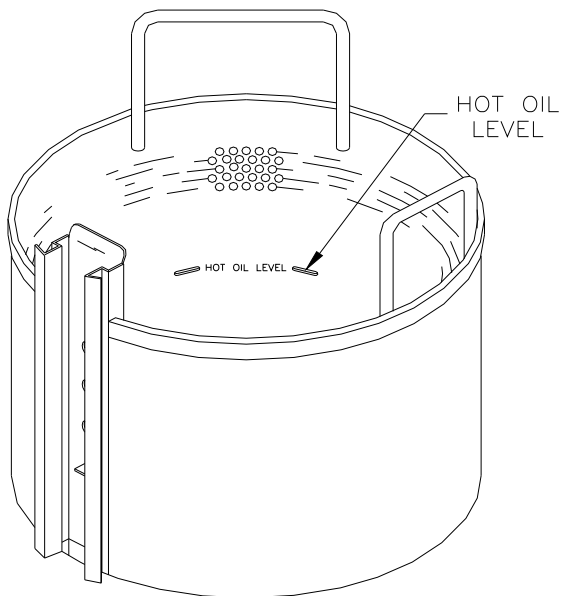
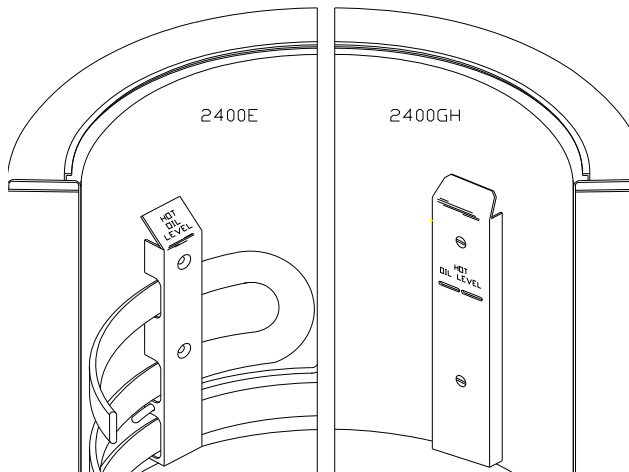

FOOD AND CONDIMENTS

Make sure the food you purchase is high quality. For best results, chicken should be fresh, trimmed for portion control, and uniform in size.

A wide variety of Broaster® Company monosodium glutamate-free condiments are available. They have all been tested for the best possible results in the unit. If using Genuine Broaster® breading and marinades, you can obtain a Trademark Authorization allowing the use of the Broaster Company trademarks in your advertising and menus.

2400GH LIGHTING INSTRUCTIONS

CE UNITS DO NOT
HAVE THE AIR
SHUTTER AS SHOWN

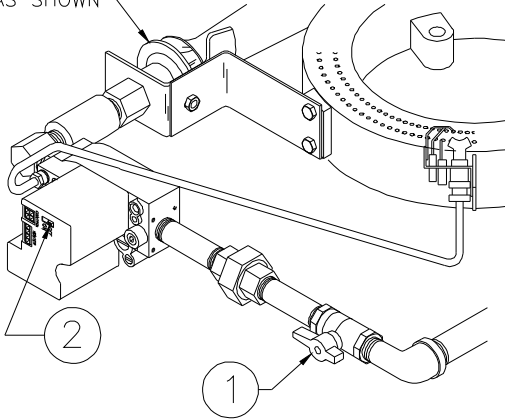

Start Up

1. Turn cook/filter switch OFF.
2. See OIL LEVEL.
3. Turn gas shut-off valve (1) ON. Wait five minutes before turning gas control ON.
4. Slide switch (2) on top of gas control to ON.*

NOTICE

The model 2400GH has an intermittent pilot burner.

This type of pilot lights when the controller calls for heat and goes out when the controller is not calling for heat.

5. To light pilot and main burners, turn cook/filter switch to COOK.

Shut Down

1. Turn cook/filter switch OFF.
2. Turn gas control switch (2) OFF.*
3. Turn gas shut-off valve (1) OFF.

*

* This switch is not used on gas pressure fryers manufactured for use in the European Union.

6 – CONTROL PANEL

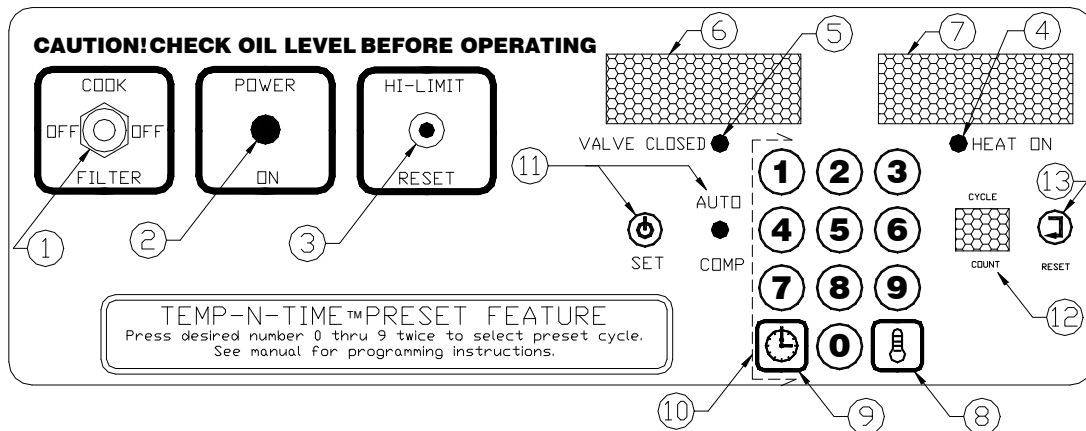

TEMP-N-TIME FAMILIARIZATION

1. **Cook/Filter Switch:** Has three positions: COOK, OFF and FILTER.
2. **Power On Indicator Light:** Illuminates when cook/filter switch is in COOK position.
3. **Hi-Limit Control:** Prevents oil temperature from exceeding 475°F. Turn unit OFF and DO NOT attempt to operate unit until it has been serviced by an authorized Broaster Company representative.

NOTICE

This control may trip during shipment. If it does, fully depress red reset button. If control “clicks” it was tripped. If not, it is correctly reset.

4. **Heat On Indicator Light:** Illuminates when oil is being heated.
5. **Valve Closed Indicator Light:** Illuminates when pressure regulating valve is CLOSED.
6. **Time Display:** Shows time countdown during a cook cycle, program values during programming, and programmed time during idle period.

7. **Temp Display:** Shows set temperature and actual temperature on demand.
8. **Cook Temperature Button:** Initiates temperature programming and displays actual temperature.
9. **Cook Time Button:** Initiates time programming.
10. **Numerical Keypad:** Enters and adjusts set point values.
11. **AUTO COMP (Automatic Time Compensation) Set Button and Light:** Indicates timing method. When OFF, controller operates as a regular timer. When ON, controller monitors oil temperature and adjusts time to compensate for fluctuations in the oil temperature.
12. **Cycle Count Display:** Increases in increments of one every time a cooking cycle is completed.
13. **Cycle Count Reset Button:** Resets the Cycle Count Display to zero.

CONTROLLER BASIC PROGRAMMING

Normal Operating Mode



Check oil level before turning cook/filter switch to COOK.

Action: Turn cook/filter switch to COOK.

Response: Temp Display alternates between number values for cook temperature, and LO (idle mode). LO disappears when oil temperature reaches cook temperature value. Time Display shows the set time in minutes and seconds.

Set Temperature

Action: Press Cook Temperature Button twice within 5 seconds.

Response: Programming mode has been entered. Flashing Temp Display reads “###F” (where ### = temperature value, such as 360°F).

Action: If desired, press keypad numbers to change displayed value. Press Cook Temperature Button once to enter new value into memory.

Response: Controller returns to idle mode.

Set Time

Action: Press Cook Time Button twice within 5 seconds.

Response: Programming mode has been entered. Flashing Time Display reads “##:##.” (##:## = time value in minutes:seconds, such as 08:00).

Action: If desired, press keypad numbers to change displayed value in minutes and seconds. Press Cook Time Button once to enter new value into memory.

Response: Controller returns to idle mode.

Set AUTO COMP (Automatic Time Compensation)

Action: Press and hold AUTO COMP Button for 3 seconds.

Response: Green light will toggle on or off.

Reset Cycle Counter

Action: Press Reset Button twice in 5 seconds.

Response: Display returns to a setting of “00.”

NOTICE

If counter is not reset before reaching “99,” upon the next cycle completion, the display will begin counting at “01.”

Normal operating programming can be done at any time without affecting presets.

PRESET COOK MODE PROGRAMMING

PROGRAMING METHOD 1

For fryers manufactured Aug 2016 or later.

Select the temperature and time, following the normal programing procedure. To save these settings for a preset. Press and hold the desired preset number for five seconds until an audible beep is sounded.

PROGRAMMING METHOD 2

For fryers manufactured before Aug 2016.

Choose Preset Cook Cycle:

Action: Press a button, 0 thru 9, corresponding to the desired preset.

Response: The TIME display shows “P__X”, where X is the preset selected.

NOTICE If a button is not pressed in 10 seconds, the display reverts to the previous display.

Action: Press the same button again,

Response: The TIME display shows the preset time, the AUTO COMP LED turns on if enabled, the TEMP display shows the preset setpoint, and the temperature will regulate to the new setpoint.

PROGRAMMING PROCEDURE (PRESET MODE)

Action: Press and hold the TIME and TEMP buttons simultaneously for 3 seconds.

Response: The TIME display and TEMP display begin flashing. The CYCLE COUNT display show “-0” indicating that the preset #0 values are displayed. The preset values for the TIME, TEMP, and AUTO COMP will be shown on the display.

Change Cook Time:

Action: Press the TIME button once.

Response: The TEMP display turns off and the TIME display flashes.

Action: Key in the desired cook time and press the TIME button to save the new setting.

NOTICE If a button is not pressed in ten seconds, the display will revert back to both the TIME and TEMP displays flashing.

Change Cook Temperature

Action: Press the TEMP button once.

Response: The TIME display turns off and the TEMP display flashes.

Action: Key in the desired temperature setting and press the TEMP button to save the new setting.

NOTICE If a button is not pressed in 10 seconds, the display reverts back to both the TIME and TEMP displays flashing.

Activate/Deactivate Auto Comp:

Action: Press and hold the AUTO COMP button for 3 seconds.

Response: AUTO COMP is enabled when the AUTO COMP LED is on and disabled when it is off.

Advance to Next Preset

Action: Press the RESET button once.

Response: The CYCLE COUNT display changes to “-1” and the presets for #1 are displayed.

Repeat the process as described. After the presets for #9 are displayed, pressing the RESET button again causes the control to return to normal operation.

SMART TOUCH FAMILIARIZATION

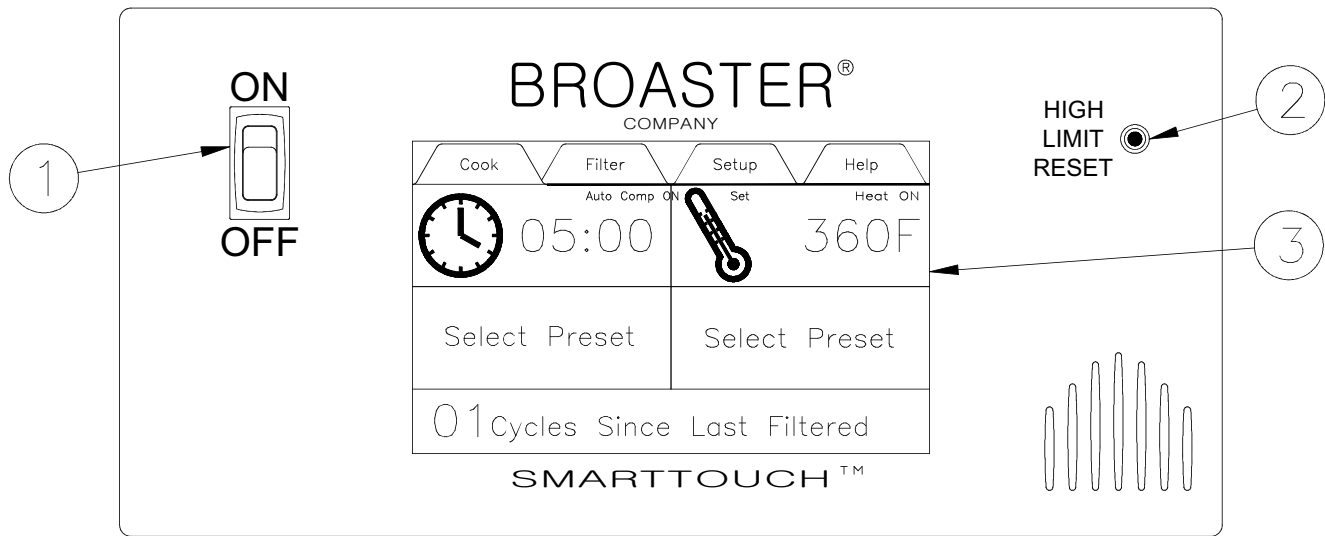

1. Power Switch: This switch has two positions: ON or OFF.
2. Hi-Limit Control: Prevents oil temperature from exceeding 475°F. When this control trips, the power to the unit will be shut down. Turn unit OFF and DO NOT attempt to operate until it has been serviced by an authorized Broaster Company representative.

NOTICE It is possible for this control to trip during shipment. If it does, fully depress red reset button. If control “clicks” it was tripped. If not, it is correctly reset.

3. Touch Control Screen: Touching this screen controls the many options of the fryer.

On initial power up you may be asked to enter the current date and time, and verify the Serial Number. Or the screen will have the word CAUTION flashing on the screen.

If the date and time entry screen appears press the box after “Month” and a keypad will appear. Enter the number of the month and press the enter key. Repeat this action for the Day, Year, Hours, Minutes, Seconds,

AM and PM boxes. When finished press the green OK button in the bottom right corner of the screen. The next display will ask you if this date should be used to establish the warranty start date. Press the green OK button.

You will then see a display asking you to verify the serial number of your fryer. Enter the serial number using the keyboard and press enter.

Note: The date/time display and the serial number display will not appear again when the power switch is turned off and back on.

If the CAUTION screen appears it is there to remind you to check the oil level before the heating elements or burner are activated. If the oil is at the proper level, press the green OK button in the bottom right corner of the screen.

Along the top of the screen are four tabs (Cook, Filter, Setup and Help) to help you setup and use your fryer.

COOK TAB

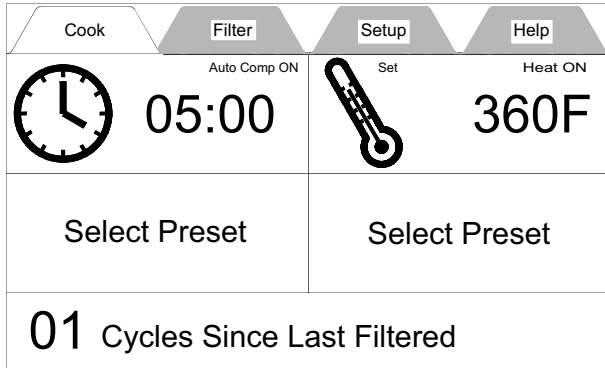

This tab is the main working screen. From this screen you can set the Cook Cycle Time, Cook Temperature or select a Product Preset.

CookTime Display:



The cook time is indicated in the box next to the clock face. To change the time press the time display twice and a keypad will appear.

Enter the cook time for the product you are cooking, as you enter the time it will appear above the keypad. To save this time press the enter key the new time will be entered and the keypad will disappear.

If no entry is made or the enter key is not pressed within 25 seconds, no change is made to the time.

When a cooking cycle is started the box below the cook time turns yellow and shows the amount of time remaining in the cycle. The right box displays "CUSTOM".

The word "CUSTOM" also replaces the tabs across the top of the display. "CUSTOM" indicates you are in manual cooking mode.

At the end of the cycle the left box alternates between red and white, the alert sounds and continues until the exhaust valve is opened by turning the small handle on the countertop from "CLOSED" to "OPEN".

Auto Comp

In the upper right corner of the cook time display is the Auto Comp indicator. It will be black if Auto Comp is off and green if Auto-Comp is on.

To turn Auto Comp on or off press the cook time display twice. When the keypad appears the Auto Comp toggle switch is in the upper right corner of the keypad. If the button is red Auto Comp is off, if it is green Auto Comp is on. Press the Auto Comp button to change it then press the enter key.

Our recommendation is that Auto Comp should be on when cooking a load of product.

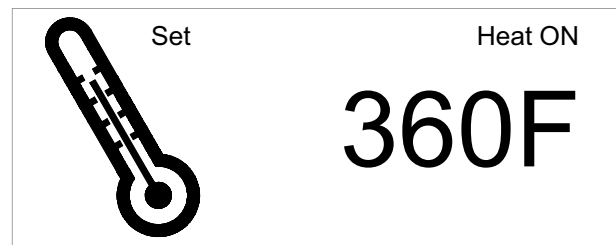

The temperature is indicated next to the thermometer.

When the fryer is turned on in the morning this box will be yellow and "Heat On" will be displayed. The temperature will alternate between "LOW" and the set temperature until the oil temperature reaches the set temperature.

There are other times when this will occur;

1. Anytime the temperature is changed.
2. After a filtering cycle.
3. When a preset is selected and the oil temperature is not at the preset temperature.

In any of these cases when the oil temperature reaches the set temperature the box turns green indicating the oil is up to the set temperature.

The temperature shown in this box can be either the “Set” temperature or the “Actual” temperature as indicated above the thermometer. To change from one to the other press and hold anywhere in the box for 3 seconds. An alert will sound when you press the box and a second alert will sound when the change is made.

To set the temperature, press the temperature box twice and a keypad will appear. Enter the temperature for the product you want to cook, as you enter the temperature, it will appear above the keypad. To save this temperature press the enter key.



There are 2 “Select Preset” boxes.

All of the Broaster Company Products are preloaded into the memory of the control and can be selected when you want to cook that product. The cook time and cook temperature for that product will be automatically entered in the Time and Temperature displays.

To select a product, press either preset box and a menu of the products will be displayed. Tap the product you wish to select.

If the wrong product comes up, don't worry! Tap the preset box again and the menu will reappear.

When the item has been selected a picture of the item will appear in the left box and a description of the item will appear in the right box. When a cook cycle is started the left box turns yellow and the time remaining in the cycle is displayed. The picture moves to the right box.

If the menu item to be cooked uses a different temperature the temperature box will either remain green meaning it is all right to start a cook cycle or it will turn yellow meaning the temperature is too low to start a load. Wait to start a cook cycle until the temperature is green.

When the temperature is green. Load the product as recommended and move the small handle on the top of the fryer from open to close. This will start the cycle timer counting down. When the load is done an alert will signal that the cooking cycle is complete.

Cycles Since Last Filtered:

01 Cycles Since Last Filtered

It is recommended the oil should be filtered every 5 loads.

This box indicates how many cook cycles have been done since the last time the oil was filtered. It is active and can be pressed at any time to go to the filter display except during a cooking cycle. Once you reach a preset number of cycles, you will be shown a filter options screen. If a filter cycle is bypassed the next cycle will turn red and start flashing.

This number can be changed and the procedure will be explained in the Setup Tab section.

FILTER TAB

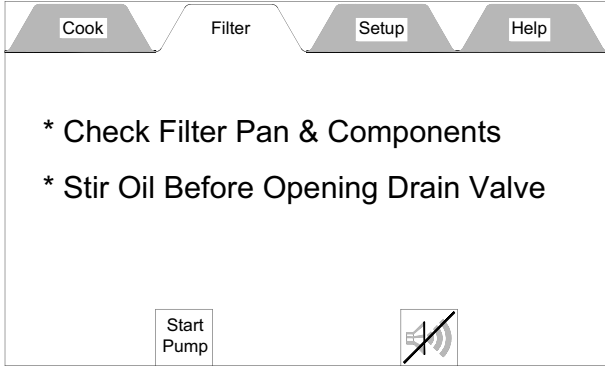

This tab is the filter motor control and has two buttons; a Start Pump button and an Alert Silence button.

There are also two reminders to observe before filtering the oil. SEE SECTION 8 - COOKING OIL CARE AND FILTERING before starting the pump motor.

When the Start Pump button is pressed the filter running display appears as shown below.



The timer in the middle of the screen starts counting up. When it reaches 5:00 minutes an alert sounds and a reminder flashes (see below) to close the drain valve. To silence the alert press the button with the speaker on it. DO NOT press the Stop Pump button.

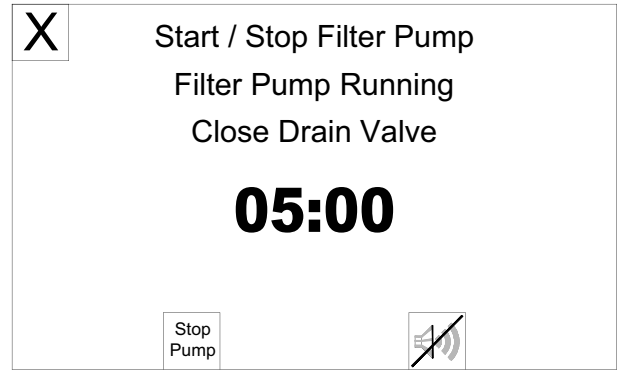

Press STOP PUMP after the oil is completely returned to the cooking well or you can leave the pump running and it will automatically stop when the counter says 10:00 minutes. See display below.

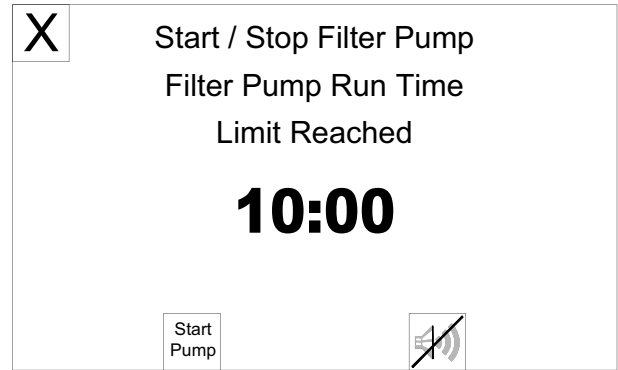

To return to the Cook Tab, press the red X in the upper left corner. The Caution Display will appear advising the oil level be checked. If the oil level is OK press the green OK button.

SETUP TAB

This tab may or may not be secured. If it is unsecured the Pin Disabled display will appear as shown below. Press the OK button to continue.

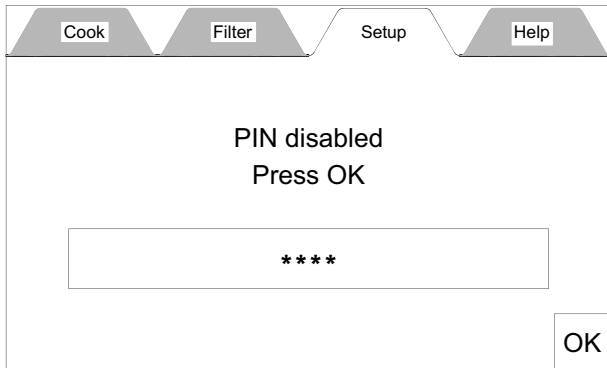

If this tab is secured the Enter Pin display will appear as shown below.

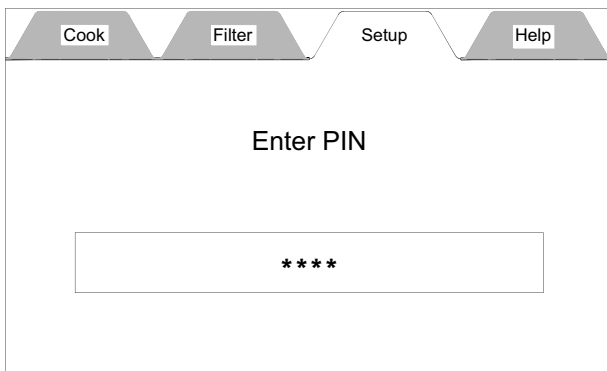

If the Pin number is known, press the box and a keypad will appear. Enter the PIN number and press Enter.

Setup Display:

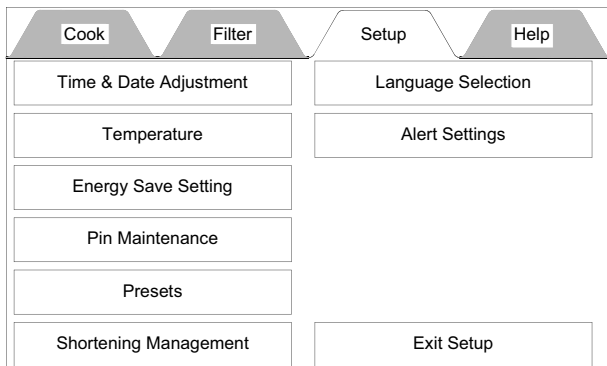

Time & Date Adjustment:

Pressing this option opens the Set Date & Time display.

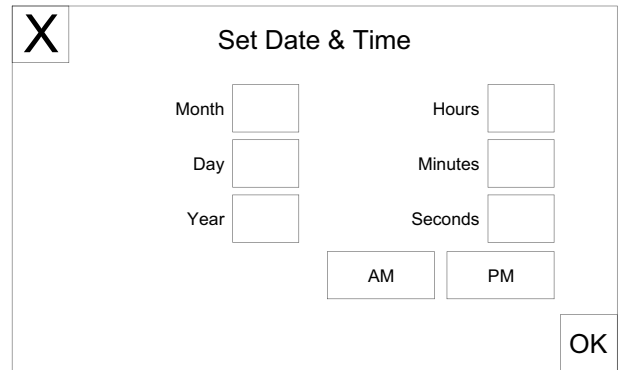

To set the date and time, press the box after "Month" and a keypad will appear. Enter the number of the month and press the enter key. Repeat this action for the Day, Year, Hours, Minutes, Seconds, AM and PM boxes. When finished press the green OK button. To leave this display without making a change press the red X or the green OK.

Temperature:

Pressing this option opens the Temperature Settings Display.

The only thing that can be set in this display is the temperature scale, either Degrees F (fahrenheit) or Degrees C (Celsius).

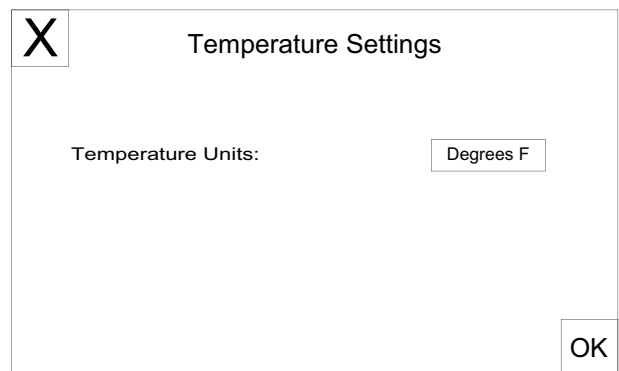

Pressing the Degrees box switches the units. Then press OK.

Energy Save Setting:

Pressing this option opens the Energy Saving Settings display.

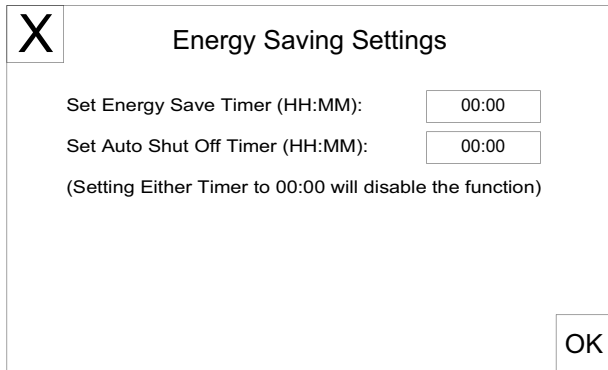

The screen displays the title "Energy Saving Settings" with a close button (X) in the top left. It contains two input fields: "Set Energy Save Timer (HH:MM):" with a value of "00:00" and "Set Auto Shut Off Timer (HH:MM):" with a value of "00:00". Below these is the text "(Setting Either Timer to 00:00 will disable the function)". An "OK" button is located in the bottom right corner.

You have two options on this display:

OPTION 1: Energy Saving Option.

The fryer will go into this mode when the specified idle time has passed. When the fryer goes into the energy saving mode the oil temperature will drop to 270° F (132° C) and remain there until the fryer is prompted by pressing the green OK button, to resume the normal cooking temperature. When the fryer enters the energy saving mode the display shown below appears.

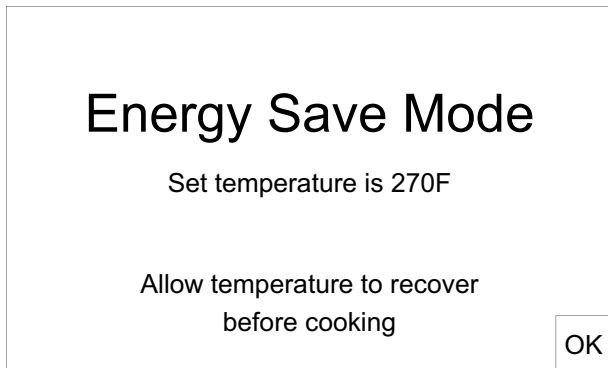

The screen displays the title "Energy Save Mode" in large text. Below it, it says "Set temperature is 270F". Further down, it says "Allow temperature to recover before cooking". An "OK" button is located in the bottom right corner.

When the OK button is pressed the display returns to the normal Cook Tab display and the temperature will be yellow and Low and the set temp will be alternating. **DO NOT** start cooking until the temp display is green.

Option 2: Auto Shut Off Timer.

When this option is set, the control will shut off all heaters, and the display shown below will appear.



The screen displays the title "Heat Off" in large text. Below it, it says "due to inactivity". Further down, it says "Hit 'OK' to resume and allow temperature to recover before cooking". An "OK" button is located in the bottom right corner.

Follow the instructions on the screen to resume use of the fryer.

Pin Maintenance:

Pressing this option opens the Pin Maintenance display.

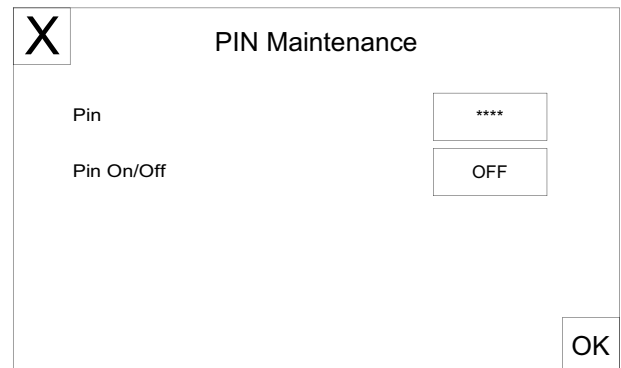

The screen displays the title "PIN Maintenance" with a close button (X) in the top left. It contains two input fields: "Pin" with a value of "****" and "Pin On/Off" with a value of "OFF". An "OK" button is located in the bottom right corner.

Presets:

Pressing this option opens a list of products with a picture of the product and the cook time and cook temperature pre-loaded.

This is where the product preset is either shown or not shown as a preset on the Cook Tab.

Select Preset or	Add New	Load Menu	Export Menu
# 1	<input type="checkbox"/>	Chicken 8pc Mixed FRESH	
# 2	<input type="checkbox"/>	Chicken Popcorn Cajun IQF	
# 3	<input type="checkbox"/>	Chicken Popcorn Regular IQF	
# 4	<input type="checkbox"/>	Chicken Tenders Home Style IQF	
# 5	<input type="checkbox"/>	Chicken Tenders Regular IQF	
# 6	<input type="checkbox"/>	Burrito Bean'n Beef IQF	
# 7	<input type="checkbox"/>	Burrito Breakfast IQF	
# 8	<input type="checkbox"/>	Burrito Pizza IQF	

By default all products will be shown. To turn any product off, press the item once and the Edit/Create Preset display will appear.

Stage	Temperature	Time	Comp On / Off	Active
1	360F	05:00	On	Yes
2	000F	00:00		
3	000F	00:00		

OK

Here you can edit the name of the of the product, change its position on the list, set the cook time and temperature, set Auto Comp to be on or off during the cooking cycle and whether or not this item should be active as a preset on the Cook Tab.

Creating a new product or deleting a product on the list will be described later.

Name Edit:

To edit the name of the current product press the Edit / Enter Preset Name bar and a typewriter keyboard will appear. The cursor will be at the end of the name. To change the name press the BACK button and the cursor will delete the name one letter each time the BACK button is pressed.

Delete the letters until you get to the place where you want to start making the change. To get the numbers and symbols to come up press the Symbol key.

When you have completed entering the changed name press the ENTER key.

Position Edit:

To change the position of this item on the menu list, press the Edit / Enter Preset Number bar and a number pad will appear. Enter the number of the position you want this item to appear at then press the ENTER key.

Time & Temperature Edit:

Most of the cooking will be done on stage 1. To edit this feature press the button and a number pad will appear. Enter the desired cooking temperature or time and press the ENTER button. If a number is entered and the ENTRY button is not pressed within 30 seconds the number pad will disappear and no changes will be made.

Comp On / Off:

This button toggles Auto Comp on or off.

Active:

This button allows the item to be shown in the preset menu list of the Cook Tab. If the button says Yes the item appears on the list if No it does not.

You can quickly tell when a product is not active because the name and number of the item will be greyed out.

ADD NEW:

Pressing this button opens a display to enter a new product to the menu list. This display is similar to the Edit display except all information must be added.

Stage	Temperature	Time	Comp On / Off	Active
1	000F	00:00	On	Yes
2	000F	00:00		
3	000F	00:00		

To enter the name press the Edit / Enter Preset Name bar and enter the name of the new product.

The Preset Number automatically defaults to the next number after the last item on the list. This can be changed by pressing the Edit / Enter Preset Number bar and entering the number where you want this item to appear.

Set the cook temperature and cook time the same way as when editing a preset.

Set Auto Comp and Activity accordingly.

Press the green OK button to save the new product.

Menu Transfer:

The Smart Touch control allows a revised menu to be transported from one fryer to other fryers which also have a Smart Touch control. This is done from the Preset tab using the Load Menu and Export Menu buttons along the top of the display.

Select Preset or	Add New	Load Menu	Export Menu
# 1	<input type="checkbox"/>	Chicken 8pc Mixed FRESH	
# 2	<input type="checkbox"/>	Chicken Popcorn Cajun IQF	
# 3	<input type="checkbox"/>	Chicken Popcorn Regular IQF	
# 4	<input type="checkbox"/>	Chicken Tenders Home Style IQF	
# 5	<input type="checkbox"/>	Chicken Tenders Regular IQF	
# 6	<input type="checkbox"/>	Burrito Bean'n Beef IQF	
# 7	<input type="checkbox"/>	Burrito Breakfast IQF	
# 8	<input type="checkbox"/>	Burrito Pizza IQF	

EXPORT MENU:

When you make changes to the menu on one fryer and want to put the same menu on other fryers with the Smart Touch Control you can export the revised menu from this fryer to the Flash Drive and load it onto the other fryers.

Plug the flash drive into the USB port in the front panel above the control panel. Press the Export Menu button on the Preset menu display.

Press the Export Menu button once and the control will ask you for a filename. Press the Enter Menu File Name bar and a keyboard will appear. Enter a name you will recognize then press the ENTER Button.

NOTICE

The file name can only be 8 characters long.

When the ENTER key is pressed a box will appear that says Exporting Menu... with a progress bar.

When the export is complete the box will say "Menu Exported". Press the OK button and the Preset display will appear. Remove the flash drive from the USB port.

LOAD MENU:

Menu changes that have been downloaded to a Flash Drive can be loaded onto another fryer with Smart Touch control.

Plug the flash drive into the USB port in the front panel above the control panel. Press the Load Menu button on the Preset menu display.

When the display appears there may be more than one menu. Press the bar for the menu you want loaded and a “Loading Menu...” box will appear with a progress bar.

When the menu is loaded a box will appear saying “Menu Loaded”. Press the OK button and the Preset display will appear.

Remove the flash drive from the USB port.

SHORTENING MANAGEMENT:

Pressing this option opens the Shortening Management Display.

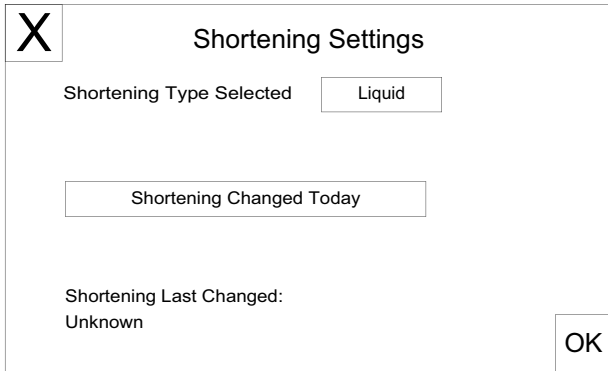

Pressing the button next to Shorting Type toggles between “Liquid” and “Solid”.

Pressing the “Shortening Changed Today” bar enters today’s date and time as a reminder when the oil was last changed. This also resets the “Cycles Since Last Filtered” counter to 00 on the Cook Tab.

LANGUAGE SELECTION:

Pressing this option will allow you to change the language used in all displays. (This option is not yet active)

ALERT SETTINGS:

Pressing this option allows you to set conditions for several features.

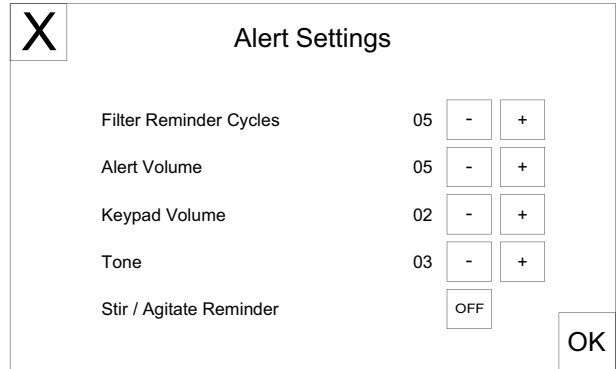

The numbers left of the boxes indicate the current setting. They can be changed by pressing the “-” or “+” buttons.

Filter Reminder Cycles: This sets the number of cook cycles between each oil filter cycle. Broaster Company recommends 5 cook cycles however, you can set it as you desire.

Alert Volume: This should be set loud enough to be able to hear it above any other noises in the kitchen.

Keypad Volume: It should be loud enough to hear while making changes in front of the fryer or when operating the fryer.

Tone: There are a range of tones from low to very high. Chose the one that suits your operation.

Stir/Agitate Reminder: This alert appears when 3 conditions occur.

1. When the fryer is first turned on in the morning, this reminder will appear after the oil comes up to the set temperature.
2. After a filter cycle has been completed this reminder will appear after the oil comes up to the set temperature.
3. If the fryer has been sitting idle for 2 hours or longer this reminder will appear will alert you to stir the oil to get it to a uniform temperature.

After making the adjustments on this display press the green OK button to save the entries.

To go back to the Cook display either press the “Exit Setup” button or the “Cook” Tab.

HELP TAB

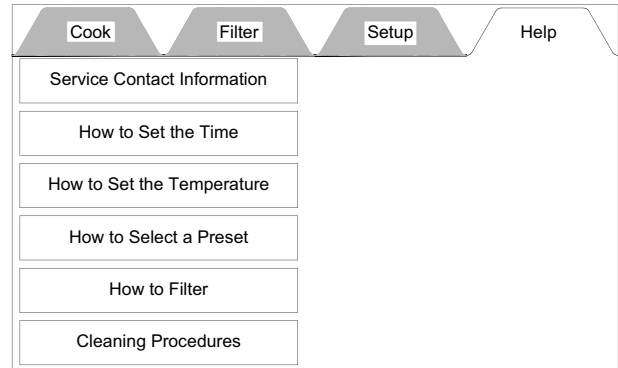

This display provides instructions for the items in the boxes. They are available at any time to help you set up the control to cook product.

7 – COOKING WEIGHT, TEMPERATURE AND TIME

FRESH PRODUCTS

⚠ WARNING ALWAYS COOK BROASTER FOODS UNTIL THE INTERNAL TEMPERATURE REACHES THE FOLLOWING MINIMUMS:

Chicken, White: 170°F;
Chicken, Dark: 180°F;
Corn Dogs/Pork: 160 to 170°F;
Fish: 155°F

The charts below give suggested temperature and time settings. Actual cook times may vary depending on a product's internal temperature before cooking. Times indicated below assume AutoComp is ON.

NOTICE

Increase cook time when cooking frozen or oversized product.

Use our methods of food preparation and cooking procedures for the best possible results.

MAXIMUM LOAD

Fresh bone-in chicken:
 9.6 kg (21 lb)

⚠ WARNING

Placing more than the recommended weight of fresh product or product that is over-wet in the cooking basket will increase the amount of surge boiling in the cooking well.

PRODUCT	WEIGHT/THICKNESS	TEMPERATURE	TIME
Fresh Chicken 8 or 9 Piece Cut	0.90 - 1.02 kg (2.00 - 2.25 lb)	182° C (360° F)	7:15 - 7:45 minutes
	1.02 - 1.13 kg (2.25 - 2.50 lb)	182° C (360° F)	7:45 - 8:15 minutes
	1.13 - 1.25 kg (2.50 - 2.75 lb.)	182° C (360° F)	8:15 - 9:00 minutes
	1.25 - 1.36 kg (2.75 - 3.00 lb)	182° C (360° F)	9:00 - 9:30 minutes
	1.36 - 1.47 kg (3.00 - 3.25 lb)	182° C (360° F)	9:30 - 10:00 minutes
	1.47 - 1.59 kg (3.25 - 3.50 lb)	182° C (360° F)	10:00 - 10:30 minutes
Whole Chicken	1.02 - 1.13 kg (2.25 - 2.50 lb)	182° C (360° F)	12:00 - 13:00 minutes
Potatoes	Quartered	182° C (360° F)	7:00 - 8:00 minutes
Pork Ribs	0.90 kgs (2.00 lb) and under	182° C (360° F)	6:00 - 7:00 minutes
Pork Chops	19.05 mm (3/4 inch) thick	182° C (360° F)	5:00 minutes
Liver	6.35 mm (1/4 inch) thick	182° C (360° F)	1 1/2 minutes
Fish	0.09 kg (3 oz) Filets	182° C (360° F)	3:00 - 4:00 minutes
Onion Rings	9.53 - 12.70 mm (3/8 - 1/2 inch) thick	182° C (360° F)	2:00 - 3:00 minutes

INDIVIDUALLY QUICK FROZEN (IQF) CHICKEN, FROZEN



ALWAYS COOK ALL BROASTER FOODS

UNTIL THE INTERNAL TEMPERATURE REACHES THE FOLLOWING MINIMUMS:

- Chicken, White: 170°F;**
- Chicken, Dark: 180°F;**
- Corn Dogs/Pork: 160 to 170°F;**
- Fish: 155°F**

Keep uncooked product frozen at 0°F or below at all times.

Maximum Load Size:

6 chickens (48 pieces)

PRODUCT	MAXIMUM LOAD	TEMPERATURE	TIME
Thighs	30 pieces	168° C (335° F)	15:00 - 17:00 min.
Legs	48 pieces	168° C (335° F)	15:00 - 17:00 min.
Breasts	24 pieces	168° C (335° F)	17:00 - 19:00 min.
Wings	60 pieces	168° C (335° F)	12:00 - 14:00 min.
Mixed Load	48 pieces	168° C (335° F)	17:00 - 19:00 min.

BROASTER FOODS COOKING CHART FOR 2400 PRESSURE FRYER

All cook times are approximate and will vary depending on load size, etc.

Product Description	Package Description	Product Number	Lbs/ Case	Cooking Time	Cooking Temperature	Approx. Load - Kgs (Lbs.)	
						MIN	MAX
Jumbo Popcorn Chicken	2/5# bags	96262	10	4 - 4.5 Min.	182°C (360°F)	.91 kg (2 lb.)	5.44 kg (12 lbs)
Cajun Jumbo Popcorn Chicken	2/5# bags	96277	10	4 - 4.5 Min.	182°C (360°F)	.91 kg (2 lb.)	5.44 kg (12 lbs)
Chicken Tenders	2/5# bags	96641	10	5 - 6 Min.	182°C (360°F)	.91 kg (2 lb.)	5.44 kg (12 lbs)
Zesty Home Style Chicken Tenders	2/5# bags	96349	10	5 - 6 Min.	182°C (360°F)	.91 kg (2 lb.)	5.44 kg (12 lbs)
Chicken Fillets	2/5# bags	96638	10	6 - 7 Min.	182°C (360°F)	.91 kg (2 lb.)	5.44 kg (12 lbs)
Traditional Wings	2/5# bags	96261	10	8 - 10 Min.	182°C (360°F)	.91 kg (2 lb.)	5.44 kg (12 lbs)
Hot 'N Spicy Wings	4/5# bags	96639	20	8 - 10 Min.	182°C (360°F)	.91 kg (2 lb.)	5.44 kg (12 lbs)
Boneless Buffalo Wings	2/5# bags	96318	10	5 - 6 Min.	182°C (360°F)	.91 kg (2 lb.)	5.44 kg (12 lbs)
Fully-Cooked Oven Roasted Chicken Wings	2/5# bags	96351	10	6 - 7 Min.	182°C (360°F)	.91 kg (2 lb.)	5.44 kg (12 lbs)
Chicken Gizzards	Bulk Packed	96271	10	4 - 6 Min.	182°C (360°F)	.91 kg (2 lb.)	5.44 kg (12 lbs)
Jumbo Corn Dogs	Bulk Packed	96661	10	Thawed 6 - 7 Min.	182°C (360°F)	.91 kg (2 lb.)	5.44 kg (12 lbs)
Jumbo Corn Dogs	Bulk Packed	96661	10	Thawed 7 - 8 Min.	168°C (335°F)	.91 kg (2 lb.)	5.44 kg (12 lbs)
Jumbo Corn Dogs	Bulk Packed	96661	10	Frozen 13 - 14 Min.	168°C (335°F)	.91 kg (2 lb.)	5.44 kg (12 lbs)
Pork Tenderloin	Bulk Packed	96313	9.75	3 - 3.5 Min.	182°C (360°F)	.91 kg (2 lb.)	1.81 kg (4 lbs)
Deluxe Pizza Burritos	48 in 7 trays	96316	15	6.5 - 7.5 Min.	182°C (360°F)	.91 kg (2 lb.)	1.81 kg (4 lbs)
Deluxe Beef 'n Bean Burritos	48 in 7 trays	96317	15	5.5 - 6.5 Min.	182°C (360°F)	.91 kg (2 lb.)	1.81 kg (4 lbs)
Deluxe Breakfast Burritos	48 in 7 trays	96323	15	6.5 - 7.5 Min.	182°C (360°F)	.91 kg (2 lb.)	1.81 kg (4 lbs)
Catfish Tender Strips	Bulk Packed	96340	10	3.5 - 4 Min.	182°C (360°F)	.91 kg (2 lb.)	5.44 kg (12 lbs)
Hand-Breaded Style Catfish Fillets	Bulk Packed	96354	10	4 - 5 Min.	182°C (360°F)	.91 kg (2 lb.)	5.44 kg (12 lbs)
Premium Cod Fillets (2 oz. Natural Cut)	2/5# bags	96329	10	4 - 5 Min.	182°C (360°F)	.91 kg (2 lb.)	5.44 kg (12 lbs)
Premium Cod Fillets (4 oz. Natural Cut)	2/5# bags	96295	10	5 - 6 Min.	182°C (360°F)	.91 kg (2 lb.)	5.44 kg (12 lbs)
Premium Beer-Battered Recipe Shrimp (tail-off)	Bulk Packed	96286	8	2.5 - 3 Min.	182°C (360°F)	.91 kg (2 lb.)	4.54 kg (10 lbs)
Potato Wedges	6/5# bags	96698	30	4 - 4.5 Min.	182°C (360°F)	.91 kg (2 lb.)	4.54 kg (10 lbs)
Potato Slices	6/5# bags	96258	30	3 - 3.5 Min.	182°C (360°F)	.91 kg (2 lb.)	4.54 kg (10 lbs)
Italian-Style 3-Cheese Mozzarella Sticks	4/3# bags	96279	12	1¼ - 1½ Min.	182°C (360°F)	.91 kg (2 lb.)	4.54 kg (10 lbs)
Beer Battered Onion Rings	20/8 oz. bags	96287	10	1¼ - 1½ Min.	182°C (360°F)	.91 kg (2 lb.)	4.54 kg (10 lbs)
Natural Cheddar Nuggets	Bulk Packed	96324	7	1¼ - 1½ Min.	182°C (360°F)	.91 kg (2 lb.)	4.54 kg (10 lbs)
Jalapeno Peppers	4/3# bags	96325	12	1¾ - 2¼ Min.	182°C (360°F)	.91 kg (2 lb.)	4.54 kg (10 lbs)

ALWAYS COOK ALL BROASTER FOODS UNTIL THE INTERNAL TEMPERATURE REACHES THE FOLLOWING MINIMUMS: Chicken, White - 170°F; Chicken, Dark - 180°F; Corn Dogs/Pork - 160°F to 170°F; Fish - 155°F

8 – COOKING OIL CARE AND FILTERING

OIL CARE

IMPORTANT

- Store cooking oil at room temperature: 65° - 75° F.
- Do not reuse the oil container.
- Keep oil away from heat and flames.
- Do not store oil near oxidizing agents.



Use care when handling hot oil. Oil could splash causing serious burns.

Maximum oil life depends on proper care. See FILTERING and CLEANING. It is very important if the finished product is to be presentable and edible. Useful oil life can be affected by many things:

Oil Quality: Poor quality oil will require replacement more often.

Temperature: Lowering oil temperature setting during slow periods or between business rushes will extend useful oil life.

Volume: The more product cooked, the more often oil will need filtering and replacing.

Type of Coating and Seasoning Used: Ingredients in some coatings can affect product appearance and shorten the useful oil life.

Amount of Care and Filtering Oil

Receives: DO NOT leave any crumb buildup in oil, on cooking well, or on food basket. See FILTERING. Oil will need replacing more often if improperly maintained. Straining methods only remove crumbs. Using a built-in filter, Broaster® filter paper and Broaster® filtering compounds can increase useful oil life up to 200%.

How can you tell if oil should be replaced? It will show signs of increased smoking or foaming. If not discarded, safety and product quality could be sacrificed.

FILTERING

Filter oil after cooking approximately 95 lb of product, between rush periods and always at the end of each day. Filter oil at 360°F.

⚠ WARNING DO NOT use filter pan to transport hot oil. Hot oil could splash, causing serious burns.

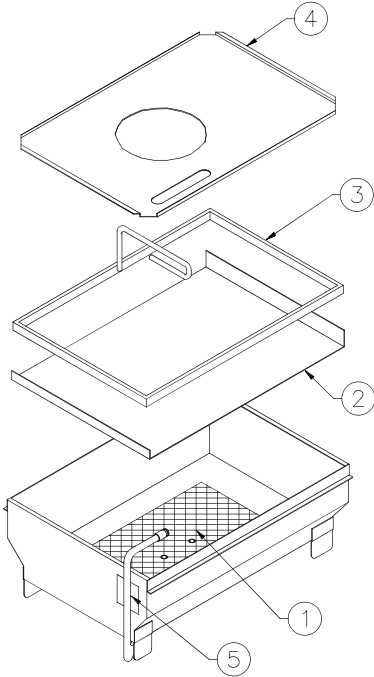

Be sure filter components are assembled correctly. The correct order is (1) Filter Screen on bottom of filter pan, (2) Filter Paper, (3) Filter Hold Down, three cups of Bro-Clean filtering media on top of filter paper, and/or 15 oz. of XL filtering COMPOUND to cooking well, and (4) Filter Cover. For best results change paper after each filter cycle.

1. Be sure filter pan, with components, is installed under unit properly. Ensure O-ring is installed on (5) Riser Line and is aligned with suction line. Turn cook/filter switch OFF and OPEN cooking well cover.

2. Using a ramrod, stir oil in a circular motion. This will aid in draining crumbs. Lower cover, pull over cooking well and open drain valve slowly. If valve becomes obstructed with crumbs, use ramrod to unblock valve.

⚠ CAUTION DO NOT allow ramrod point to hit bottom of filter pan. Point of ramrod can penetrate filter paper, allowing crumbs and filter compound to pass through filter lines.

3. When oil is drained, remove basket support grate, if present, and clean separately. Lower cover assembly and pull cover over cooking well completely but DO NOT CLOSE. Turn cook/filter switch to FILTER. When oil is flowing out of drain, close drain valve and pump approximately 8 inches of oil into cooking well.
4. Being careful of hot oil and cooking well components, use bottom brush to scrub cooking well starting at the top and cleaning downward. On 2400E, clean inside and between heating elements. Use element brush to clean between cooking well and heating elements. Be sure crumbs do not cover temperature sensor. See the following figure for sensor location.

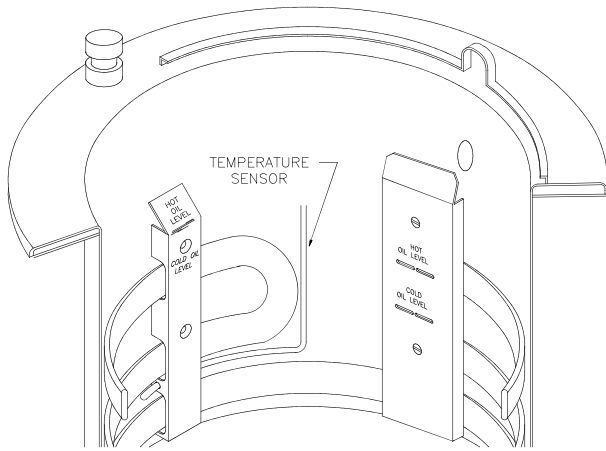

- Slowly agitate brush in oil to dislodge any crumbs caught in it. Rinse cooking well using oil remaining in brush when dipped in oil. Drain remaining oil and crumbs. Pull cover over cooking well but **DO NOT CLOSE**. Turn cook/filter switch to **FILTER**. After 5 minutes, push cover back and raise cover assembly. Close drain valve.

2400GH: Turn off cook/filter switch and replace basket support grate in bottom of cooking well.

- Turn cook/filter switch to **FILTER**. When air bubbles appear turn cook/filter switch **OFF**.

WARNING Be sure hot oil is at **HOT OIL LEVEL**.

- When filter pan has cooled, remove and discard filter paper and filtering compound. Using a clean cloth or paper towel, wipe crumbs from filter hold down, filter pan interior and top & bottom of filter pan cover. Never use soap and water.

WARNING Rags or paper containing cooking oil can catch fire if exposed to heat. Laundering will not remove the oil. Dispose of all oil-soiled papers and rags in a trash container that is in a ventilated area away from all cooking equipment or other heat sources such as direct sunlight.

WARNING **DO NOT** operate unit without filter pan and filter pan cover in its proper position. Filter pan cover must be wiped clean after each filtering cycle.

- Return clean filter pan (equipped with all necessary clean filter components including cover) under the fryer before operation.

FILTERING HINTS

- Never allow solid shortening to solidify in filter pan or lines.
- For maximum filtration, recirculate oil. When hot oil is drained into filter pan, turn cook/filter switch to **FILTER**. Let motor run for five minutes with drain valve open. This may extend useful oil life.

NOTICE Ensure cook/filter switch is **OFF** to avoid splashing of oil if motor protector reset button is used.

9 – CLEANING

⚠ DANGER DO NOT heat or boil water in a pressure fryer.

Disconnect main power supply. Keep cover and pressure regulating valve OPEN when cooking well contains water. If cover is CLOSED on a well holding hot or boiling water, a large quantity of scalding water could spray out when cover is opened causing serious burns.

⚠ CAUTION Broaster® cooking well cleaner is an irritant. DO NOT take internally. Prolonged skin contact may cause irritation and dryness. Direct eye contact may cause irritation, redness and temporary blurred vision. Ingestion may cause nausea, diarrhea, mucosal and gastric irritation. See first aid instructions on container.

⚠ WARNING When cleaning with water, use Broaster® cooking well cleaner #99500. DO NOT use soaps and detergents. Cooking well cleaner removes unwanted contaminants while also neutralizing harmful acids. These acids, if not removed, may damage cooking well and filter system. To ensure cover remains OPEN when cleaning, install cleaning flag #12814 over latch column. Cleaning flag is supplied with each new unit and in cooking well cleaner. Additional cleaning flags can be ordered.

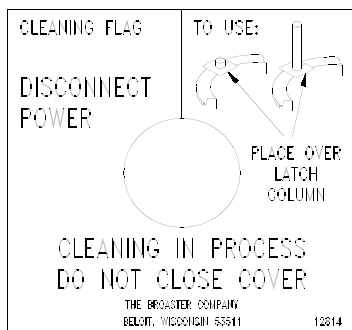

COOKING WELL

NOTICE

Cover and Splash Shield cleaning should be completed before cooking well is cleaned.

1. Turn power switch OFF and disconnect main power supply.
2. Remove filter pan (if unit has one) from under unit.
3. Drain and discard used oil.
4. OPEN cover and install cleaning flag #12814 over latch column. Remove basket support grate and clean separately if present.

NOTICE

Quarterly cleaning of Probe Guard (gas and electric) should be done at this point. See “PROBE GUARD & BASKET GUIDES” on page 9-4.

5. Close drain valve. Fill a separate container with 2 gallons of hot water and thoroughly dissolve Broaster® cooking well cleaner (use 93624 BROASTER WELL CLEANER CUP for appropriate amount). Add to cooking well then finish filling well to 1” below the pressure release port.
6. Soak with cover OPEN for a minimum of 15 minutes. Alternate method: soak overnight up to 12 hours.
7. Drain and discard cleaning mixture. Place pail back under drain valve, connect main power supply and turn on pump of 10 seconds to purge filter lines.

8. Clean cooking well using a non-metallic heavy duty commercial scouring pad that is USDA approved.
9. Rinse cleaning utensils and cooking well with water. Turn pump on again for 10 seconds to purge the filter lines. Drain and discard rinse water.
10. If equipped, replace cleaned basket support grate in bottom of cooking well.
11. Close drain valve. Wipe inside of cooking well dry before filling with new oil.

FOOD BASKET

Clean the food basket daily. **DO NOT** put food basket in a dishwasher. Use warm water and a low suds organic household dish cleanser. Rinse basket with vinegar and water solution (1/2 cup vinegar per gallon of water). Rinse with clear water and completely dry before returning to oil.

UNIT SURFACES

Frequently wipe off excess oil and crumbs with a clean cloth or paper towel. **DO NOT** use harsh abrasives and chemicals.

⚠ WARNING Rags or paper containing cooking oil can catch fire if exposed to heat. Laundering will not remove the oil. Dispose of all oil-soiled papers and rags in a trash container that is in a ventilated area away from all cooking equipment or other heat sources such as direct sunlight.

CONDENSATE PAN

Check liquid level several times daily. Empty as needed.

⚠ WARNING Water and hot oil **DO NOT** mix. **DO NOT** pour contents into cooking well or filter pan. Hot oil could splash causing serious burns.

SLIDE RODS

Clean daily along with the cover. See “COVER” on page 9-2. Wipe with a clean cloth or paper towel. No lubrication is necessary.

COVER

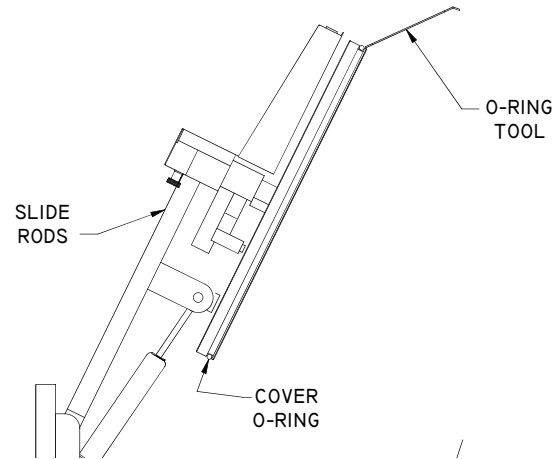

NOTICE

Keep a spare O-ring on hand in case of accidental damage.

1. OPEN cover and slide back until it stops.
2. Raise the cover assembly.
3. Rotate cover handle to CLOSED position. Using O-ring tool #12791 or a small dull tool such as a spoon handle, remove cover O-ring.
4. Clean O-ring using warm water only. **DO NOT** use detergents. Hold wet rag around O-ring and pull through several times.
5. Clean O-ring groove using the O-ring tool #12791 to remove any material stuck in the groove and the O-ring groove brush 14502 and water to remove any residue, Clean cover top and bottom. Use a non-metallic heavy duty commercial scouring pad that is USDA approved to clean cover.

- Remove any oil or grease build-up from Pressure Relief Valve and Pressure Gauge Ports on bottom of cover.
- After cleaning, completely dry. Lubricate O-ring with clean liquid shortening. Install O-ring in O-ring groove.

SPLASH SHIELD

⚠ WARNING Allow cover assembly to cool before cleaning. Hot surfaces could cause serious burns.

Clean the two-piece splash guard according to the following instructions:

- OPEN cover and slide back.
- Rotate cover handle (1) to a centered position.

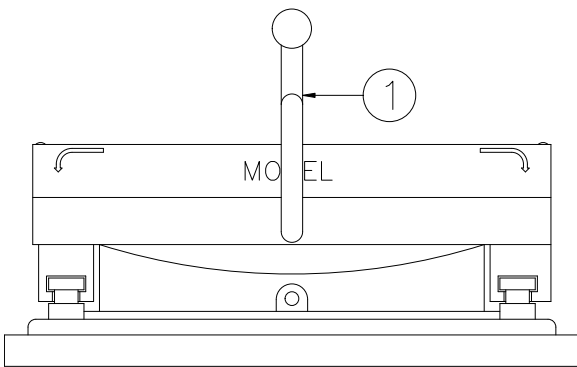

- Loosen thumbscrews (2) attaching back splash shield (3) to splash shield (4).

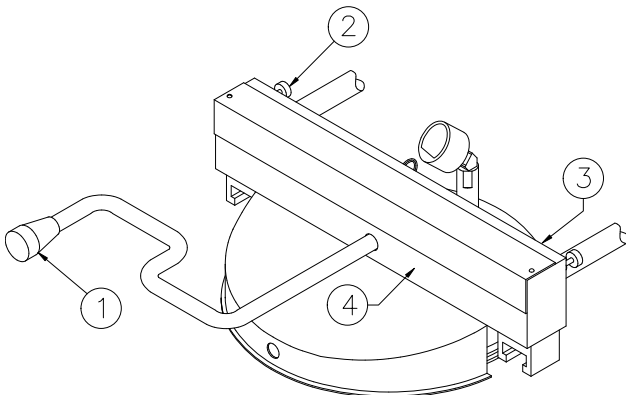

- Slide splash shield (4) forward and up toward the end of the cover handle (1).
- Clean the top and underside of splash shield and top of the cover.

NOTICE Ensure back splash shield (3) and splash shield (4) are assembled correctly after cleaning. The cover may not close correctly if they are not.

- Assemble in reverse order.

GAS SPRING COVERS

⚠ WARNING Allow cover assembly to cool before cleaning. Hot surfaces could cause serious burns.

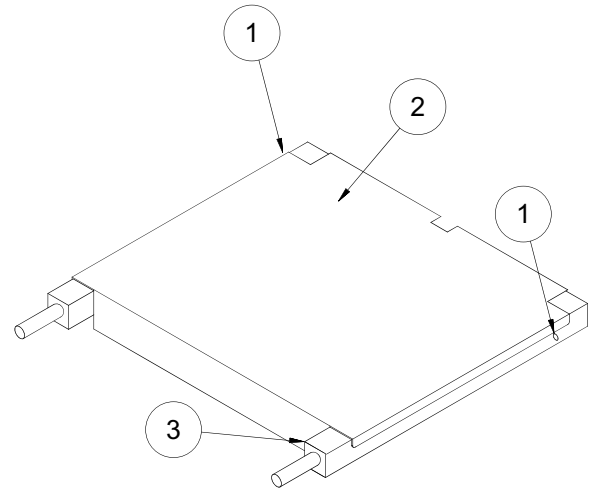

Clean the gas spring cover as follows:

- Lower the cooking well cover and slide forward until it stops.
- Loosen thumb screws (1) attaching gas spring cover (2) to yoke assembly (3).
- Raise the cover off the yoke assembly.
- Clean the top and underside of the gas spring cover and the yoke assembly.

- Wipe gas springs with clean cloth or paper towel.
- Assemble in reverse order.

PROBE GUARD & BASKET GUIDES

At least once every 3 months, while cleaning the cooking well, the probe guard and basket guides must be removed so that any build-up that collects behind them can be cleaned.

- After emptying the oil and before filling with cleaning solution, remove the probe guard using a flat screwdriver, or a 7/16" wrench for the Model 2400E. Remove the probe guard. (See illustrations below.)
- Very carefully remove any debris that is caked on or around the temperature sensor probe and the hi-limit capillary.
- On electric fryers, remove the 3 basket guides using a flat screwdriver. Leave the element spacers in place. Carefully clean any build-up that has collected behind the basket guides.

NOTICE

It is often difficult to get the basket guides to line up for installation.

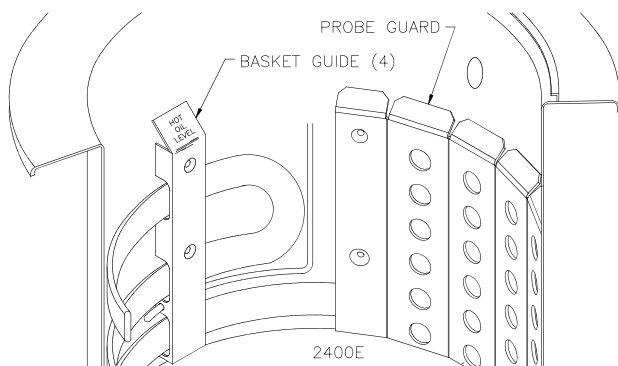

CAUTION Using too much force in this area may damage the hi-limit capillary or the temperature sensor probe. If either of these components are damaged, the unit will be inoperable until the component is replaced.

- Leaving the probe guard and basket guides off, fill the cooking well with cleaning solution and clean normally. The probe guard and basket guides can be placed in the cooking well while soaking.
- After draining the solution, carefully clean area around the probes and behind the basket guides, and inside the probe guard and basket guides with a non-metallic scouring pad to completely remove any build-up. Rinse and dry the cooking well.
- Reinstall the probe guard and basket guides with the appropriate hardware using medium (blue) threadlock on screw threads.

CAUTION It is very important to periodically check the screws fastening the probe guard and basket guides to ensure that they do not loosen. If you find that they are coming loose, tighten them immediately.

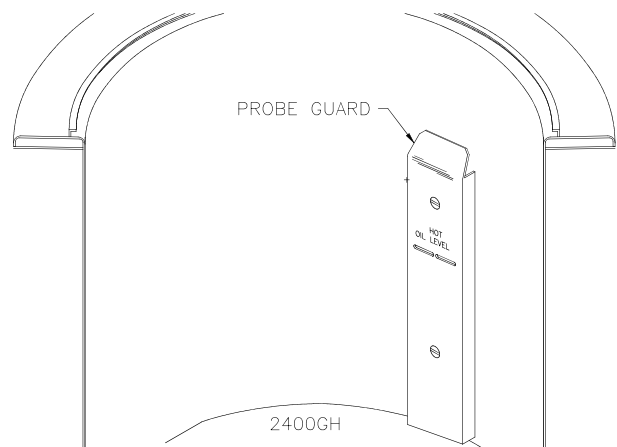

MINIMUM PREVENTIVE MAINTENANCE REQUIREMENTS



Never clean the fryer with a water jet type cleaning machine.

	DAILY	AT OIL CHANGE	QUARTERLY	YEARLY
Clean Cooking Well		X		
Clean Condensate Pan	X			
Clean Oil Build-up Under Unit			X	
Clean Pressure Relief Valve port & Pressure Gauge Port		X		
Clean Cover and Splash Guard		X		
Clean Food Basket	X			
Clean Temperature Sensor			X	
Clean Filter Pan Cover	After each filtering cycle			
Filter Cooking Oil	See FILTERING			
Clean and Lubricate O-Ring		X		
Slide Rods	X			
Gas Spring Cover		X		
Probe Guard & Basket Guides			X	

NOTICE

If cooking volume is high, perform above requirements more frequently.

10 – SHUTDOWN

NIGHTLY

⚠ WARNING If at any time the **POWER ON** light does not turn off when the cook/filter switch is moved to the **OFF** position, contact your local Broaster Company representative for service immediately.

⚠ WARNING Rags or paper containing cooking oil can catch fire if exposed to heat. Laundering will not remove the oil. Dispose of all oil-soiled papers and rags in a trash container that is in a ventilated area away from all cooking equipment or other heat sources such as direct sunlight.

1. Turn cook/filter switch OFF.
2. Filter cooking oil. See “FILTERING” on page 8-2.
3. **2400GH:** Turn gas valve and manual gas shut off valve to OFF.
4. Wipe oil and crumbs from unit surfaces with a clean cloth.
5. Clean food basket.
6. Clean condensate pan.

SEASONAL

⚠ WARNING Rags or paper containing cooking oil can catch fire if exposed to heat. Laundering will not remove the oil. Dispose of all oil-soiled papers and rags in a trash container that is in a ventilated area away from all cooking equipment or other heat sources such as direct sunlight.

1. See “Cooking Oil Care and Filtering” on page 8-1. Discard cooking oil.
2. See “Cleaning” on page 9-1.
3. Turn main circuit breaker OFF and unplug electrical cord.
4. **2400GH:** Turn gas valve, manual gas shut off valve and main gas supply OFF.
5. Clean condensate pan.
6. Wipe oil and crumbs from unit surfaces with a clean cloth.
7. Lubricate cover O-ring and food basket with olive oil.
8. CLOSE cover and pressure regulating valve.

11 - TROUBLESHOOTING

All adjustments and repairs shall be made by an authorized Broaster Company representative.

ELECTRICAL TIPS

COMPLAINT	CAUSE	REMEDY
POWER ON light not illuminated	<ol style="list-style-type: none"> 1. Main power OFF 2. Cook/filter switch OFF 3. Hi-limit tripped 4. Unplugged 	<ol style="list-style-type: none"> 1. Turn ON. 2. Turn to COOK. 3. Turn cook/filter switch OFF. Contact service person. 4. Plug in.
Timer will not time	<ol style="list-style-type: none"> 1. Main power OFF 2. Cook/filter switch OFF 3. Solid state controller in program mode 4. Pressure regulating valve OPEN 	<ol style="list-style-type: none"> 1. Turn ON. 2. Turn to COOK. 3. Exit program mode. 4. CLOSE.
HEAT ON light not illuminated	<ol style="list-style-type: none"> 1. Main power OFF 2. Cook/filter switch OFF 3. Solid state controller in program mode 4. Oil temperature has reached programmed temperature 	<ol style="list-style-type: none"> 1. Turn ON. 2. Turn to COOK. 3. Exit program mode. 4. Unit ready for cooking.

SOLID STATE CONTROLLER TIPS

COMPLAINT	CAUSE	REMEDY
Display reads FAIL	1. There is a controller failure.	1. Turn cook/filter switch OFF. Contact service person.
Display reads HI	1. Oil temperature too high.	1. Turn cook/filter switch OFF. Contact service person.
Display reads PROB	1. There is a temperature sensor probe failure.	1. Turn cook/filter switch OFF. Contact service person.
Display reads CHEC	1. Gas valve not ON (2400GH)	1. Turn ON.
	2. Pilot light will not light (2400GH)	2. Turn ON manual gas shut off valve.
	3. Open or faulty wall fuse	3. Check wall fuse or circuit breaker.
	4. Oil temperature not rising properly	4. Turn cook/filter switch OFF. Contact service person.



SMART TOUCH CONTROLLER TIPS

COMPLAINT	CAUSE	1800E REMEDY	1800GH REMEDY
Display reads HEATER FAULT	Oil temperature not rising properly	* Call for service	* Remove anything causing a draft by the unit (like a fan). * Turn on the gas valve. * Call for service
Display is blank	Screen not calibrated	* With unit off, place finger on screen and hold while turning unit on. Touch the small box in the upper left corner until it moves to the upper right corner, then touch it again until it moves to the lower left corner, then touch it again until it disappears. Controller will reboot. * Call for service	
Display doesn't respond when touched			
Display reads PROBE FAULT	* Probe circuit is open or shorted *Probe wires are connected in reverse *Temperature changes more than 100F in two seconds	* Call for service	* Call for service
Display reads HI TEMP FAULT	Temp reaches 415F	* Call for service	* Call for service
Display reads INTERNAL FAULT	Internal fault detected	* Call for service	* Call for service
Display reads C1 FAULT	C1 contactor is stuck in the closed position	* Call for service	* Call for service

GAS TIPS

COMPLAINT	CAUSE	REMEDY
Pilot burner will not ignite	<ol style="list-style-type: none"> 1. Gas valve OFF 2. Air in pilot gas line 3. Gas shut-off valve OFF 4. Incoming gas pressure too high 	<ol style="list-style-type: none"> 1. Slide switch to ON. 2. See “2400GH LIGHTING INSTRUCTIONS” on page 5-3. 3. Turn ON. 4. Install regulator to control gas pressure.
Main burner will not ignite	<ol style="list-style-type: none"> 1. Pilot burner not lit 2. Gas control OFF 3. Controller in program mode 4. Cook/filter switch OFF 5. Hi-limit tripped 	<ol style="list-style-type: none"> 1. See “2400GH LIGHTING INSTRUCTIONS” on page 5-3. 2. Turn ON. 3. Exit program mode. 4. Turn to COOK. 5. Turn cook/filter switch OFF. Contact service person.

COVER, YOKE, AND LIFT TIPS

COMPLAINT	CAUSE	REMEDY
Cover hard to CLOSE	<ol style="list-style-type: none"> O-ring dry or dirty O-ring groove dirty Hard O-ring 	<ol style="list-style-type: none"> Clean and lubricate. Clean. Replace.
Cover will not OPEN  WARNING Never use force to OPEN cover.	<ol style="list-style-type: none"> O-ring dry or dirty O-ring groove dirty Hard O-ring Pressure not released Pressure regulating valve out of adjustment 	<ol style="list-style-type: none"> Clean and lubricate. Clean. Replace. OPEN pressure regulating valve. Contact service person.
O-ring Break  CAUTION DO NOT rest basket on top flange of cooking well. Damage to area in contact with O-ring can cause leaking under pressure or O-ring failure.	<ol style="list-style-type: none"> O-ring groove dirty Nicks in cooking well or cover 	<ol style="list-style-type: none"> Clean. Remove.
Cover will not stay in raised position	<ol style="list-style-type: none"> Weak gas spring 	<ol style="list-style-type: none"> Contact service person.
Pressure Gauge does not indicate rising pressure when exhaust valve is closed.	<ol style="list-style-type: none"> Port is plugged Pressure gauge is damaged 	<ol style="list-style-type: none"> Clean port on bottom of cover. Replace pressure gauge.

PRESSURE SYSTEM TIPS

⚠ DANGER DO NOT attempt to tighten, repair or replace any fitting, line or component when there is pressure in the cooking well. Hot oil could spray out under pressure causing serious burns.

COMPLAINT	CAUSE	REMEDY
No pressure	1. Pressure regulating valve OPEN	1. CLOSE.
	2. Pressure regulating valve dirty or blocked open	2. Contact service person.
	3. Leaks around cover O-ring	3. Replace O-ring.
Excess pressure		1. Turn cook/filter switch OFF. Contact service person.

PRODUCT TIPS

Fresh Chicken

COMPLAINT	CAUSE	REMEDY
Product too light	1. Low oil temperature	1. Check cook temperature.
	2. No coating	2. Check procedures.
	3. Not done	3. Increase cook time.
	4. Food basket overloaded	4. Decrease load.
Product too dark	1. High oil temperature	1. Check cook temperature.
	2. Wrong coating	2. Check procedures.
	3. Breaded too long	3. Discard.
	4. Old oil	4. Change oil.
	5. Breaded too wet	5. Drain thoroughly prior to breading.
Product not done	1. Low oil temperature	1. Check cook temperature.
	2. Food basket overloaded	2. Decrease load.
	3. Cook time too short	3. Increase cook time.
No flavor	1. Improper marination	1. Check procedures.
White spots	1. Product stuck together	1. Float basket while loading.
	2. Food basket overloaded	2. Decrease load size.
Dark spots	1. Dirty oil	1. Filter or replace oil.

Individually Quick Frozen (IQF) Chicken

COMPLAINT	CAUSE	REMEDY
Product too light	<ol style="list-style-type: none"> 1. Low oil temperature 2. Not done 3. Food basket overloaded 	<ol style="list-style-type: none"> 1. Check cook temperature. 2. Increase cook time. 3. Decrease load.
Product too dark	<ol style="list-style-type: none"> 1. High oil temperature 2. Overcooked 3. Oil old 4. Thawed and refrozen 	<ol style="list-style-type: none"> 1. Check cook temperature. 2. Decrease cook time. 3. Change oil. 4. Keep product at 0°F or below.
Product not done	<ol style="list-style-type: none"> 1. Low oil temperature 2. Food basket overloaded 3. Cook time too short 	<ol style="list-style-type: none"> 1. Check cook temperature. 2. Decrease load. 3. Increase cook time.
No flavor	<ol style="list-style-type: none"> 1. Overcooked 2. Old product 	<ol style="list-style-type: none"> 1. Check cook time. 2. Discard
White spots	<ol style="list-style-type: none"> 1. Product stuck together Food basket overloaded 	<ol style="list-style-type: none"> 1. Float basket while loading. 2. Decrease load size.
Dark spots	<ol style="list-style-type: none"> 1. Dirty oil 	<ol style="list-style-type: none"> 1. Filter or replace.

FILTERING TIPS

COMPLAINT	CAUSE	REMEDY
<p>Motor will not start</p> <p>⚠ WARNING Turn cook/filter switch to OFF position to avoid splashing of oil when motor protector reset button is pushed.</p>	<ol style="list-style-type: none"> 1. Overload tripped 2. Cook/filter switch OFF 3. Open or faulty wall fuse or circuit breaker 	<ol style="list-style-type: none"> 1. Wait for overload to cool. Push red motor protector reset button located on rear of motor. 2. Turn to FILTER. 3. Check wall fuse or circuit breaker.
<p>Motor hums but will not start</p>	<ol style="list-style-type: none"> 1. Solidified shortening in pump 2. Crumbs in pump 	<ol style="list-style-type: none"> 1. Turn cook/filter switch OFF. Contact service person. 2. Turn cook/filter switch OFF. Contact service person.
<p>Motor starts but will not pump</p>	<ol style="list-style-type: none"> 1. Filter pan not completely installed 2. O-ring on riser line not installed 3. Solidified shortening in piping or filter pan 	<ol style="list-style-type: none"> 1. Firmly push filter pan in. 2. See FILTERING. 3. Turn cook/filter switch OFF. Contact service person.
<p>Motor starts but will not pump or stops at any level</p>	<ol style="list-style-type: none"> 1. Filter paper or hold down improperly installed 2. Not using enough Broaster® filtering compound 	<ol style="list-style-type: none"> 1. See “Cooking Oil Care and Filtering” on page 8-1. 2. Next filtering cycle, ensure proper amount of Broaster® filtering compound is used.
<p>Motor starts but stops pumping when oil is level with top of hold down, approximately 1 inch of oil in bottom</p>	<ol style="list-style-type: none"> 1. Filter paper improperly installed or crumbs under filter paper or hold down 	<ol style="list-style-type: none"> 1. See “Cooking Oil Care and Filtering” on page 8-1.



Broaster Company
2855 Cranston Road, Beloit, WI 53511-3991
608/365-0193
broaster.com