

Project _____
Item _____
Quantity _____
FCSI Section _____
Approval _____
Date _____



Broaster® Cold Top Refrigerator



Standard Features

- *Simplify loading* of your pressure fryer with this cold top unit. Simply take the chicken from the refrigerated area and place it into your pressure fryer.
- *Refrigeration at its best*—designed for convenience and ease of use in your Broaster kitchen.
- *Refrigerated top area*—holds a 12" x 20" pan of coated chicken, ready for cooking.
- *Additional storage*—for up to three pans of coated chicken inside.
- *Make practical use of your kitchen*—with the 27-1/2" x 11-3/4" plastic cutting board mounted on top.



Dimensions

Overall Dimensions			Counter Height	Net/Ship Weight	Cubes
W	D	H	36" (914.4 mm)	176/225 lbs	25.16
27.5" (698.5 mm)	30" (762 mm)	43" (1092.2 mm)			

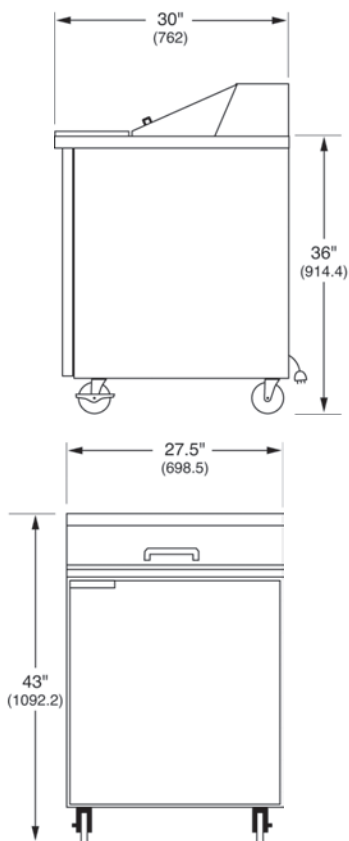

Additional Features

- Forced-air refrigeration, purposely directed maximum airflow under pans, for colder pan temperatures and uniform air circulation throughout the cabinet
- Interior has white aluminum ceiling and sides, coved corners and a stainless steel floor, for easy cleaning
- Compact 6.5 cu. ft. refrigeration
- Door is hinged on the right
- Pan rack is easily removed for cleaning
- Special interior rack stores three additional 12" x 20" pans
- Four swivel wheels, with the front two locking, for easier movability

Energy Requirements

115 volt, 60 Hz, 4.0 amps,
7' long electrical cord