

BROASTER
EQUIPMENT

Broaster® E-Series Pressure Fryer - 24E

Featured Innovations



- **Highest Energy Efficiency in Pressure Fryer Category** – electric E-Series 24E boasts the highest-level energy efficiency heating element system (15,000 watts). Ready for Energy Star application once EPA has established standards for pressure fryers.
- **Auto-Lift Feature** – reduces need to lift heavy basket providing a safer and operationally friendly work environment, making it easier to handle a large quantity of chicken.
- **Shelving & Rack System** – 4 shelves provide even cooking, uniform product appearance, and safer operator ergonomics. Sheet pan holder provides operator workspace to transfer shelves.
- **One-touch Cook Cycle** – cook cycle starts automatically with lid closure, no need to hit “Start”
- **Automatic Controlled Pressure Release** – end of cook cycle automatically triggers release of pressure within the cooking well, can be programmed for soft, controlled release.
- **More Production Capacity** – the largest 8 head capacity amongst pressure fryers. Elimination of a long manual oil filtration means more fry time.
- **Automatic Oil Filtration Between Cook Cycles** – unit automatically begins a quick filtration cycle after each cook cycle. Expect weeks of oil life compared to days of oil life in traditional units.
- **Smartdrain Technology** – detects obstructions during draining and recognizes if crumb buildup is inhibiting the flow of oil.
- **On Board Oil Replenishment** – ability to top fryer oil off easily and semi-automatically based on operator need.
- **Bulk Oil Handling** – easily connects to bulk oil input and discharge systems to eliminate employee handling of the on-board oil reservoir tank.
- **Advanced Microprocessor Controller** – easy-to-use, touch screen interface reduces training time for new employees. Bilingual interface included.



TESTED TO ANSI / NSF 4



TESTED TO UL197

Safety Features

Triple-redundant safety system is featured consisting of a chrome plated relief valve, a smooth, articulating stainless steel splash guard and a single action patented cam lock cover system.

To ensure operator convenience and safety, unit features a pressure activated cover-locking mechanism and the SmartTouch Controller which integrates an automatic pressure regulator valve, exhaust valve, and drain valve interlock.

Standard setup includes on-board oil replenishment for oil top off. Reservoir slides and tilts out for easy oil tank filling.

Available bulk oil handling connections eliminate the need for employees to handle heavy oil containers and dispose of hot oil.

Front panel door swings open and is removable to allow access to unit, keeping the panel elevated and out of the way for service.

A maximum of two screws per side allows access to any part of the machine, making it quick and easy to service.

Broaster® E-Series Pressure Fryer - 24E

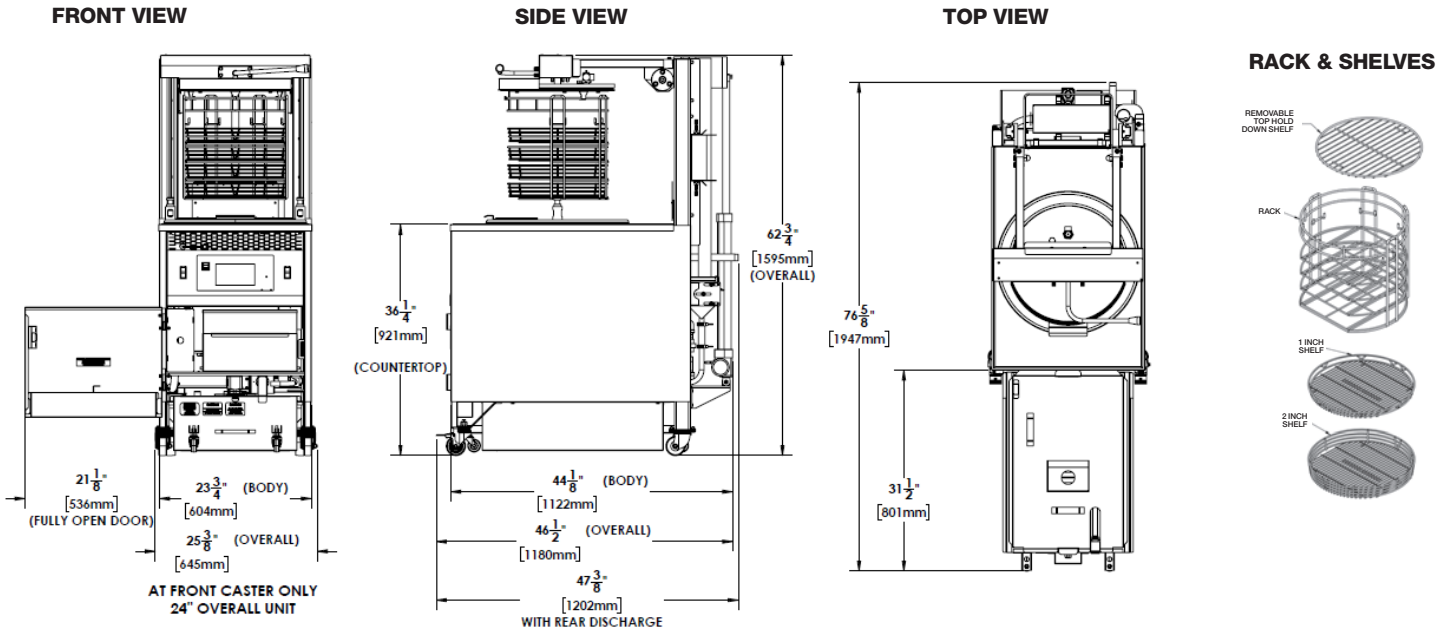

Dimensions

| Model | Fresh Chicken Capacity | Cooking Oil Capacity | Operating Pressure | Overall Dimensions | | | Counter Height | Net/Ship Weight |
|-------|---------------------------|----------------------|--------------------|--------------------|-----------|-----------|--------------------|-----------------|
| | | | | W | D | H | | |
| ES24E | 26 lbs. (64 pcs/8 hds) | 85 lbs. | 12 - 14 P.S.I. | 25.38" | 47.38" | 62.75" | 36.75" (922 mm) | 580/630 lbs. |
| | | | | (645 mm) | (1203 mm) | (1594 mm) | | |

Additional Features

Specifically designed for high volume production, cooks up to 64 pieces of fresh bone-in chicken per load in as little as 11-12 minutes when using four round, 2-head shelves.

Two options for shelving configurations to match your back-of-house process; individual shelves available in 1 inch or 2 inch heights. Flat shelves are easily removable.

Unique Auto Comp feature automatically adjusts cooking time to accommodate for varying sizes and temperatures of loads.

Perfect for all your fried chicken cooking needs, including hand breaded tenders and fillets.

Primary construction is of stainless steel built on black powdercoated steel frame with front and rear casters for mobility and ease of cleaning.

Proven round cooking well design engineered for more uniform heat distribution, durability and efficiency; no cold spots or corners. Large capacity provides more room for product, minimizes sticking and produces delicious, superior quality food.

Fully welded cooking well is made from durable 300 series stainless steel.

Specifications subject to change without notice.

Energy Requirements

15,000 watts

3 phase, 208 or 240 volt, 50/60 hz

50 amp service

220/380, 230/400, 240/415 also available

Ready for Energy Star application once the EPA has established standards for pressure fryers.



Accessories and Options

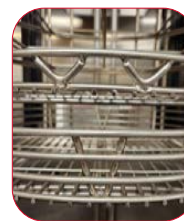

Unit Ships Standard With:
 One rack, a complete set of four shelves and two handles

Choose Between:
 1" tall sides or 2" tall sides
 Both are round and hold 2 head per shelf